

Intel® Desktop Boards D845HV and D845WN Quick Reference

This guide is written for technically qualified personnel with experience installing and configuring desktop boards.

Before You Begin

Warning and Caution	3
Safety and Regulatory Notice:	3

Desktop Board Components

D845HV Board Components	4
D845WN Board Components	6

Supported Components

8

Installation Steps

1 Installing the I/O Shield	9
2 Installing the Desktop Board	10
3 Installing the Processor Fan Heatsink Base	12
4 Installing the Processor	14
5 Installing the Processor Fan Heatsink	14
6 Installing the Memory Modules	15
7 Installing the AGP Card Retention Mechanism	17
8 Installing an AGP Card	19
9 Connecting the Fans	20
10 Attaching the IDE Drives	21

Setting the BIOS Configuration Jumper Block

22

Items on the Intel® Express Installer CD-ROM

- Product warranty
- Intel Express Installer
- *Intel® Desktop Boards D845HV and D845WN Product Guide*
- Software utilities and drivers
- Software license agreement
- Readme file

Part Number: A61046-001

Getting Help

View or download product support information from Intel's World Wide Web site: <http://support.intel.com/support/motherboards/desktop>

Documents on the Web site include:

- *Intel® Desktop Board D845HV/D845WN Technical Product Specification*
- *Intel® Desktop Board D845HV/D845WN Specification Update*

If you can't find the information you need on the Web, contact your point of purchase. The Intel Web site also includes telephone numbers and billing charges, if applicable, for Intel customer support.

Intel Corporation (Intel) makes no warranty of any kind with regard to this material, including, but not limited to, the implied warranties of merchantability and fitness for a particular purpose. Intel assumes no responsibility for any errors that may appear in this document. Intel makes no commitment to update nor to keep current the information contained in this document. No part of this document may be copied or reproduced in any form or by any means without prior written consent of Intel.

An Intel® product, when used in accordance with its associated documentation, is "Year 2000 Capable" when, upon installation, it accurately stores, displays, processes, provides, and/or receives date data from, into, and between the twentieth and twenty-first centuries, including leap year calculations, provided that all other technology used in combination with said product properly exchanges date data with it.

Intel and Pentium are trademarks and registered trademarks of Intel Corporation or its subsidiaries in the United States and other countries.

† Other names and brands may be claimed as the property of others.

Copyright © 2001, Intel Corporation. All rights reserved.

Before You Begin

Warning and Caution



WARNING

Disconnect the board's power supply from its ac power source before you connect or disconnect cables, or install or remove any board components. Failure to do this can result in personal injury or equipment damage. Some circuitry on the desktop board can continue to operate even though the front panel power switch is off.



CAUTION

Electrostatic discharge (ESD) can damage desktop board components. Install the board at an ESD-controlled workstation. If such a workstation is not available, wear an antistatic wrist strap or touch the surface of the antistatic package before handling the board.

Safety and Regulatory Notice:

See the *Intel Desktop Boards D845HV and D845WN Product Guide* for all applicable regulatory compliance statements, product certification markings, and safety and electromagnetic compatibility (EMC) standards and regulations these desktop boards are compliant with.

Replacement battery warning label provided: Place the label inside the chassis in an easy-to-see location near the battery but not on the board itself.

Intended uses: This product was evaluated as information technology equipment (ITE) for home or office use when installed into an appropriate computer chassis. Other end uses or locations may require further evaluation.



NOTE

The D845HV board layout was used in all illustrations unless otherwise noted.

Desktop Board Components

D845HV Board Components

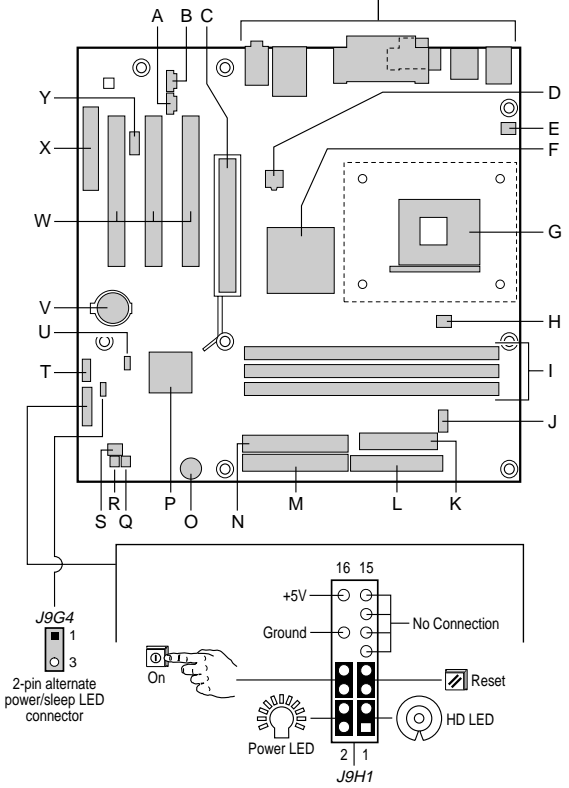
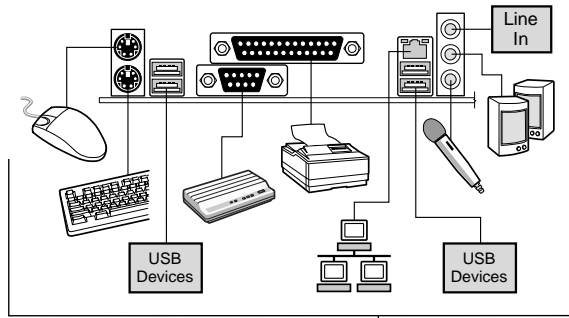

OM11984

continued

D845HV Board Components (continued)

A	CD-ROM connector (ATAPI)	N	Secondary IDE connector
B	Auxiliary line-in connector (ATAPI)	O	Speaker
C	AGP connector (1.5 V only)	P	Intel® 82801BA I/O Controller Hub (ICH2)
D	12 V processor core voltage connector	Q	SCSI hard drive activity LED connector
E	Rear chassis fan connector (tachometer input)	R	Chassis intrusion connector
F	Intel® 82845 Memory Controller Hub (MCH)	S	Front chassis fan connector
G	Processor socket	T	Front panel USB connector
H	Processor fan connector (tachometer input)	U	BIOS configuration jumper block
I	DIMM sockets	V	Battery
J	Serial port B connector	W	PCI bus add-in card connectors
K	Power connector	X	Communication and Networking Riser (CNR) (optional)
L	Diskette drive connector	Y	Front panel audio connector
M	Primary IDE connector		



CAUTION

Many of the midboard and front panel connectors provide operating voltage (+5 V dc and +12 V dc, for example) to devices inside the computer chassis, such as fans and internal peripherals. These connectors are not overcurrent protected. Do not use these connectors for powering devices external to the computer chassis. A fault in the load presented by the external devices could cause damage to the computer, the interconnecting cables, and the external devices themselves.

D845WN Board Components

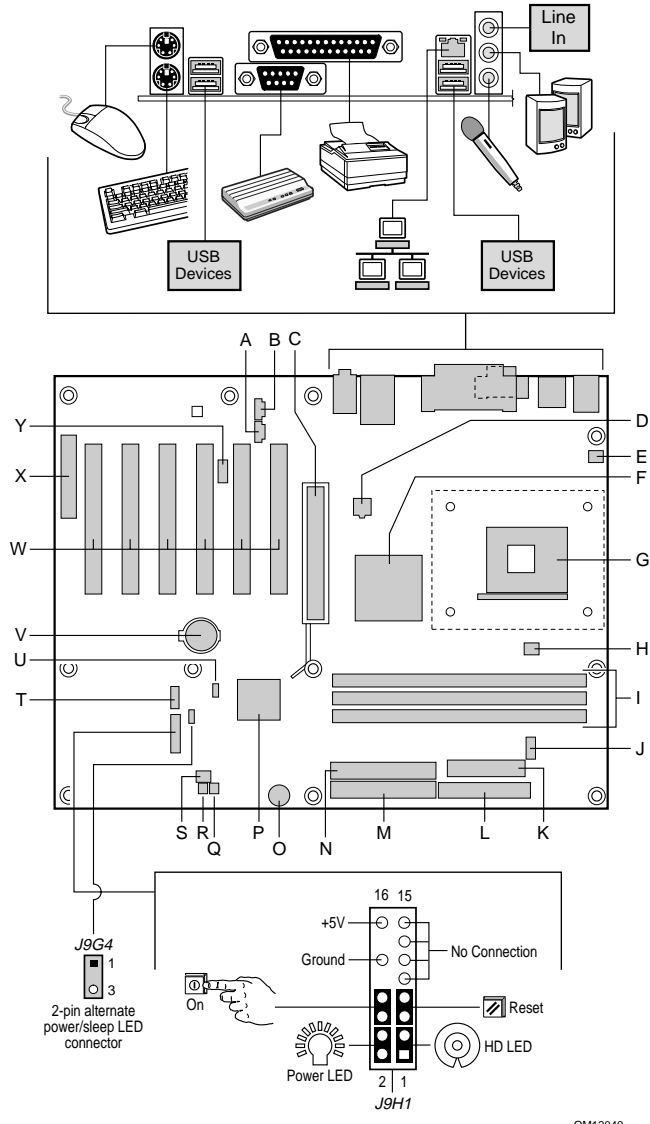

OM12040

D845WN Board Components (continued)

A	CD-ROM connector (ATAPI)	N	Secondary IDE connector
B	Auxiliary line-in connector (ATAPI)	O	Speaker
C	AGP connector (1.5 V only)	P	Intel 82801BA I/O Controller Hub (ICH2)
D	12 V processor core voltage connector	Q	SCSI hard drive activity LED connector
E	Rear chassis fan connector (tachometer input)	R	Chassis intrusion connector
F	Intel 82845 Memory Controller Hub (MCH)	S	Front chassis fan connector
G	Processor socket	T	Front panel USB connector
H	Processor fan connector (tachometer input)	U	BIOS configuration jumper block
I	DIMM sockets	V	Battery
J	Serial port B connector	W	PCI bus add-in card connectors
K	Power connector	X	Communication and Networking Riser (CNR) (optional)
L	Diskette drive connector	Y	Front panel audio connector
M	Primary IDE connector		



CAUTION

Many of the midboard and front panel connectors provide operating voltage (+5 V dc and +12 V dc, for example) to devices inside the computer chassis, such as fans and internal peripherals. These connectors are not overcurrent protected. Do not use these connectors for powering devices external to the computer chassis. A fault in the load presented by the external devices could cause damage to the computer, the interconnecting cables, and the external devices themselves.

Supported Components

Processors



CAUTION

Failure to use an ATX12V power supply, or not connecting the additional power supply lead to the D845HV or D845WN board may result in damage to the desktop board and/or power supply.

For more information on the ATX12V power supply, refer to the Intel Desktop Boards D845HV and D845WN Product Guide on the Intel Express Installer CD-ROM.

The board supports the following processors:

Type	Designation	System Bus Frequency
Intel® Pentium® 4 processor in an mPGA-478 pin package	1.4, 1.5, 1.6, 1.7, and 1.8 GHz	400 MHz

For the latest information on processors supported by the D845HV and D845WN boards, refer to the Intel World Wide Web site at:

<http://support.intel.com/support/motherboards/desktop>

Memory Module Requirements

The boards supports system memory as defined below:

- Up to three 168-pin SDRAM Dual Inline Memory Modules (DIMMs) with gold-plated contacts
- PC133 SDRAM only
- 64 Mbit, 128 Mbit, and 256 Mbit technologies for the following memory configurations:
 - 32 MB to 384 MB (64 Mbit technology)
 - Up to 768 MB (128 Mbit technology)
 - Up to 1.5 GB (256 Mbit technology)



NOTES

The D845HV and D845WN desktop boards have been designed to support DIMMs based on 512 Mbit technology up to 3 GB, but this technology has not been validated on these boards. For more information about the latest list of tested memory, refer to the Intel World Wide Web site at:

<http://support.intel.com/support/motherboards/desktop/>

- Unbuffered and non-registered single or double-sided DIMMs
- Serial Presence Detect (SPD) memory
- Non-ECC and ECC DIMMs
- 3.3 V memory only

⇒ NOTES

All memory components and DIMMs used with the desktop boards must comply with the PC SDRAM specifications. These include the PC SDRAM Specification (memory component specific), the PC Unbuffered DIMM Specification. To view or download these specifications, refer to this Intel World Wide Web site:

<http://www.intel.com/technology/memory/pcsdram/>

For information about vendors that support these memory requirements, refer to the D845HV and D845WN link on this Intel World Wide Web site:

<http://support.intel.com/support/motherboards/desktop/>

Installation Steps

1 Installing the I/O Shield

The board comes with an I/O shield. When installed in the chassis, the shield blocks radio frequency transmissions, necessary to pass emissions (EMI) certification testing, protects internal components from dust and foreign objects, and promotes correct airflow within the chassis.

Install the I/O shield before installing the board in the chassis. Place the shield inside the chassis as shown in the following figure. Press the shield into place so that it fits tightly and securely. If the shield doesn't fit, obtain a properly-sized shield from the chassis supplier.

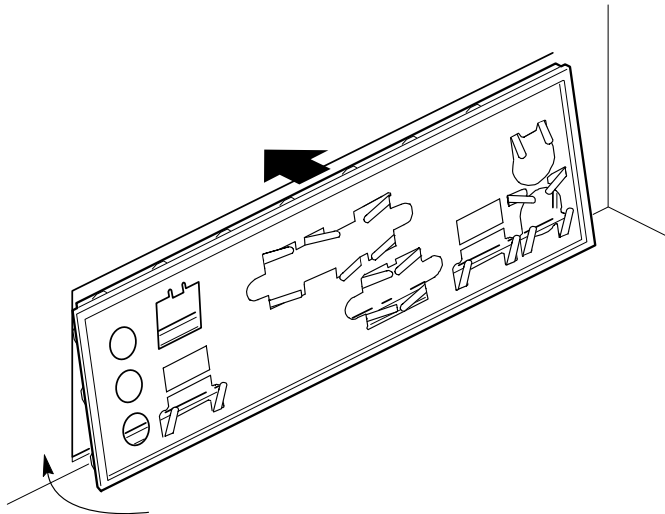

OM11543

2 Installing the Desktop Board



CAUTION

Failure to use an ATX12V power supply, or not connecting the additional power supply lead to the D845HV and D845WN boards may result in damage to the desktop board and/or power supply.

For more information on the ATX12V power supply, refer to the Intel Desktop Boards D845HV and D845WN Product Guide on the Intel Express Installer CD-ROM.

Refer to your chassis manual for specific instructions on installing and removing the board. Secure the board to the chassis standoffs using the screws.

The figure below shows the eight mounting holes for the D845HV board.

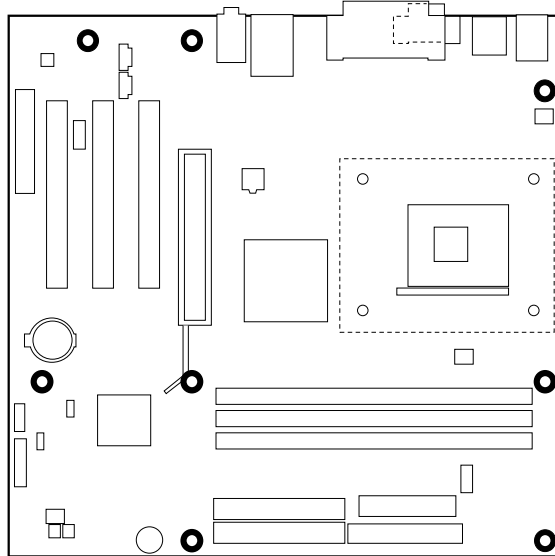

OM11982

D845HV Board Mounting Holes

The figure below shows the 11 mounting holes for the D845WN board.

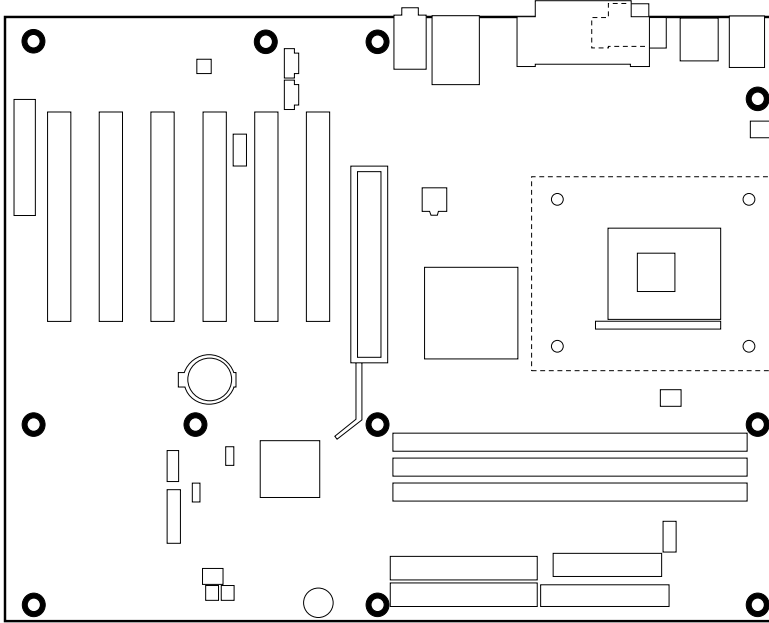

OM12080

D845WN Board Mounting Holes

3 Installing the Processor Fan Heatsink Base

NOTE

The following assembly operation should be performed after the desktop board is secured in the chassis.

The board comes with the processor fan heatsink base. Follow the instructions below to install the base to the board.

1. Observe the precautions in “Before You Begin” on page 3.
2. The processor fan heatsink base is secured to the board with four pushpins. See the location of the processor fan heatsink base mounting holes in the following figure.

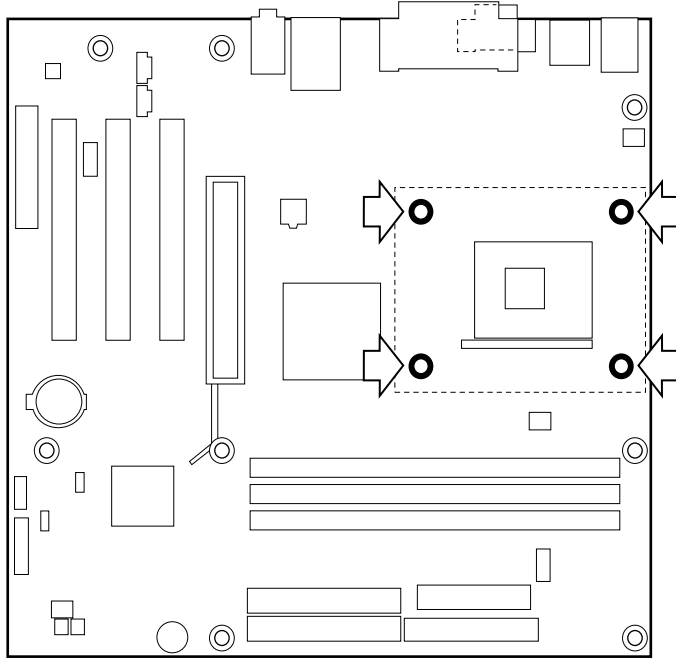

OM11983

- Align the four fasteners (B) of the processor fan heatsink RM base with the corresponding holes in the desktop board (C). Gently press the base down until all four corners snap into place. Verify that all four fasteners are fully engaged, then press down each of the four locking pushpins (A) to fully secure the base to the desktop board.

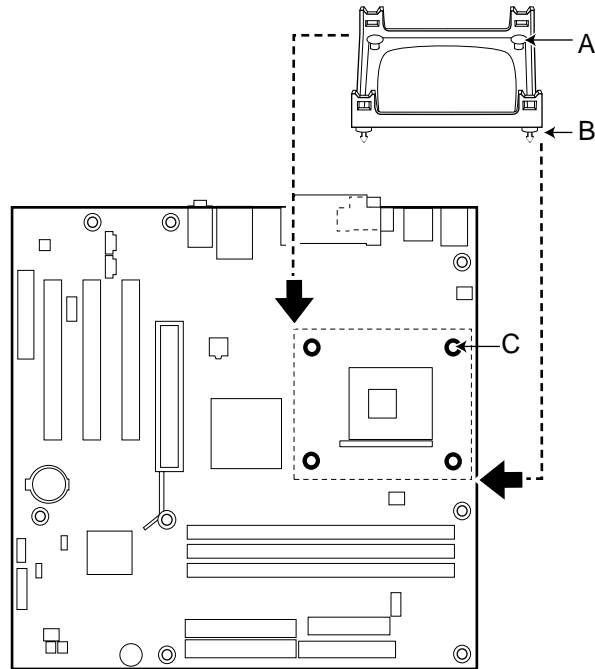

OM12096

4 Installing the Processor

1. Observe the precautions in “Before You Begin” on page 3.
2. Lift the processor socket lever.
3. Install the processor so that the corner with the triangle marking (A) is aligned with the corner where the lever is attached to the socket.
4. Lower the lever back to its original position.

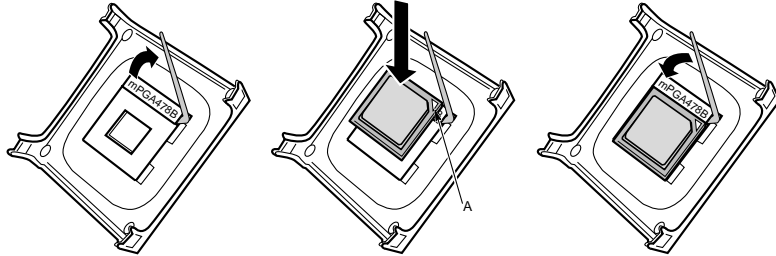

OM12078

5 Installing the Processor Fan Heatsink

For instructions on how to install the processor fan heatsink, refer to the boxed processor manual or the Intel World Wide Web site at:

<http://support.intel.com/support/motherboards/desktop>

6 Installing the Memory Modules



CAUTION

Install memory in the DIMM sockets prior to installing the AGP video card to avoid interference with the memory retention mechanism.

The D845HV and D845WN boards require that DIMMs be installed. The three DIMM sockets are arranged as Banks 0, 1, and 2 as shown in the figure below. If installing a single DIMM, install it in Bank 0. If installing two DIMMs, install them in Banks 0 and 1.

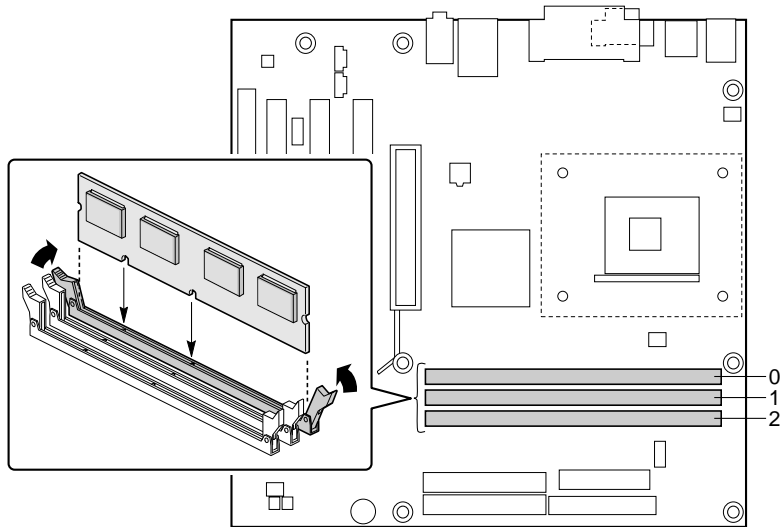

OM11986

To install DIMMs, follow these steps:

1. Observe the precautions in “Before You Begin” on page 3.
2. Turn off all peripheral devices connected to the computer. Turn off and unplug the computer.
3. Remove the computer cover and locate the DIMM sockets.
4. Remove the AGP video card (if it interferes with the DIMM clips from being easily opened and closed).
5. Holding the DIMM by the edges, remove it from its antistatic package.
6. Make sure the clips at either end of the socket are pushed away from the socket as shown above.
7. Position the DIMM above the socket. Align the two small notches in the bottom edge of the DIMM with the keys in the socket.
8. Insert the bottom edge of the DIMM into the socket.
9. When the DIMM is inserted, push down on the top edge of the DIMM until the retaining clips snap into place. Make sure the clips are firmly in place.
10. Reinstall the AGP card if you removed it before installing the DIMMs.
11. Replace the computer cover.

7 Installing the AGP Card Retention Mechanism



CAUTION

Install the AGP card retention mechanism (RM) only when using an AGP card with a retention notch (A) as shown in the figure below. Using the RM with an unnotched card may impair video operation. See the Intel Desktop Boards D845HV and D845WN Product Guide on the Intel Express Installer CD-ROM for RM removal instructions.



NOTE

All D850HV and D850WN desktop boards may not include an AGP RM. See "Installing an AGP Card" on page 19 if your boxed desktop board does not include an AGP RM.

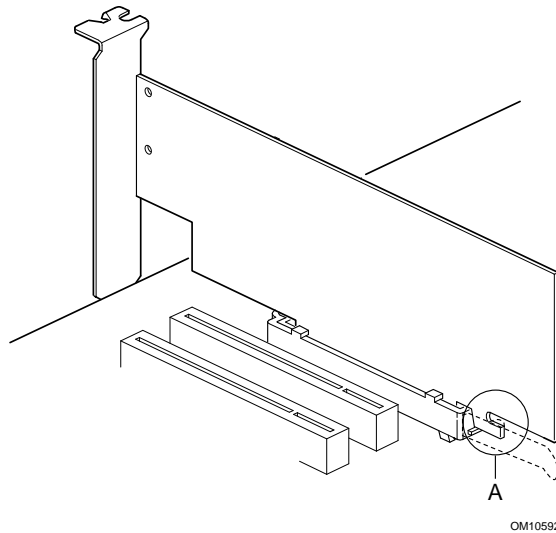

The RM encloses the board's AGP connector and stabilizes the AGP card. Place the board (component side up) on a flat, supportive surface. Follow the steps outlined below to attach the RM (A) to the AGP connector (B):

1. Observe the precautions in "Before You Begin" on page 3.
2. Locate the AGP connector on the board as shown below. Note that the board's silkscreen (C) indicates the correct final position of the lever (D) on the RM.

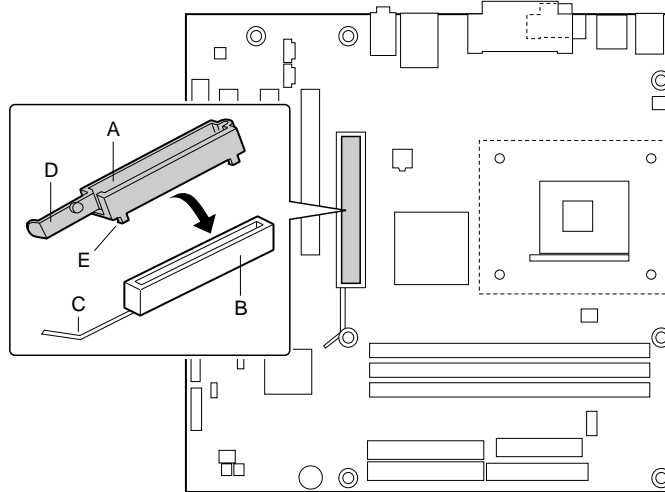

OM11980

3. Position the RM over the AGP connector as shown below.

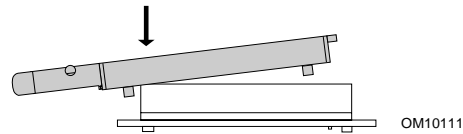

OM10111

4. Push the lever end of the RM in the direction of the arrow until the two rearmost tabs (E) spread over the end of the AGP connector.

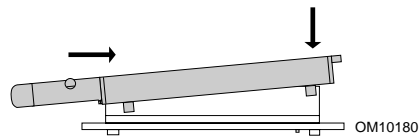

OM10180

5. Push the free end of the RM over the other end of the AGP connector and press down evenly on both ends of the RM until all four tabs click underneath the AGP connector. Do not apply unnecessary pressure to avoid damaging the board.



8 Installing an AGP Card



NOTE

The D845HV and D845WN boards are only compatible with 1.5 V AGP cards.

Follow these instructions to install an AGP card if it has a retention notch.

1. Observe the precautions in “Before You Begin” on page 3.
2. Place the AGP card in the AGP connector.
3. Press down on the card until it is completely seated in the connector and the card retention notch snaps into place below the RM.
4. Secure the card’s metal bracket to the chassis back panel with a screw.

9 Connecting the Fans

The following figure shows the location of the fan connectors. Connect the processor's fan heatsink cable to the processor fan connector on the board. Connect the chassis fan cables to the board connectors as shown in the figure below.

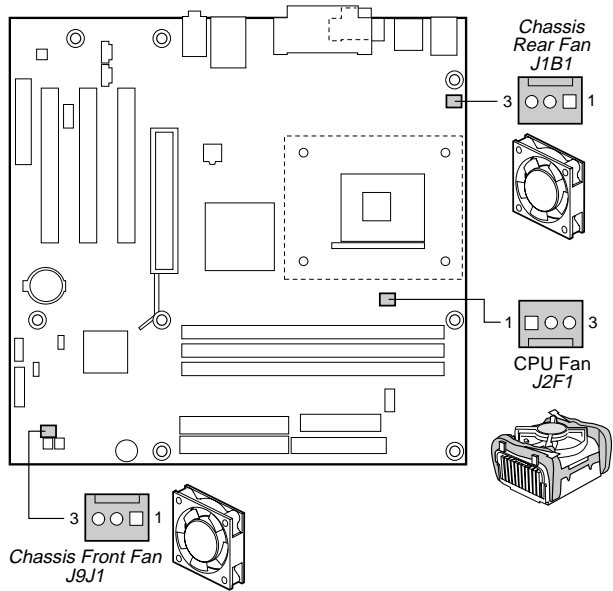

OM11985

10 Attaching the IDE Drives

The Intel® boxed desktop board package includes two IDE cables. Either cable can connect two drives to the desktop board. The cables support the Ultra DMA-33 (40-contact) or ATA-66/100 (40-contact, 80-conductor) transfer protocols and are backward compatible with drives using slower IDE transfer protocols.

The cable will work correctly only when oriented as shown in the figure below. For correct cable function:

1. Observe the precautions in “Before You Begin” on page 3.
2. Attach the cable end with the single connector (A) to the board.
3. Attach the cable end with the two closely spaced connectors (B) to the drives.

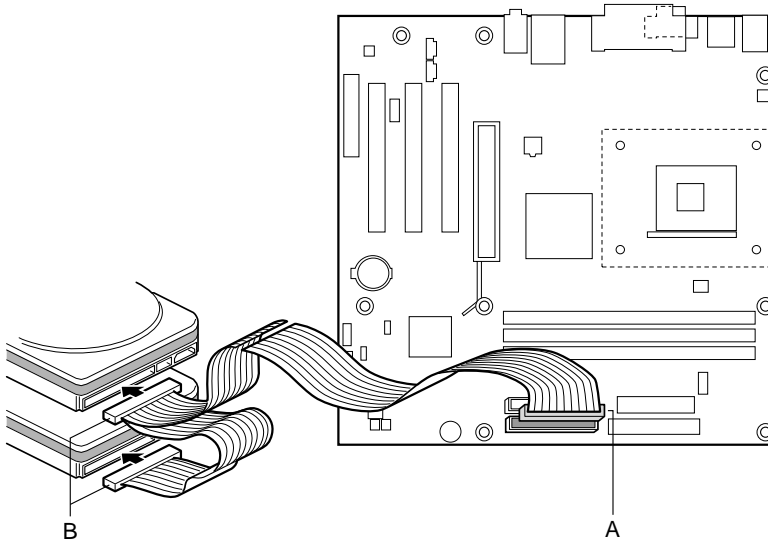

OM11988

Setting the BIOS Configuration Jumper Block



CAUTION

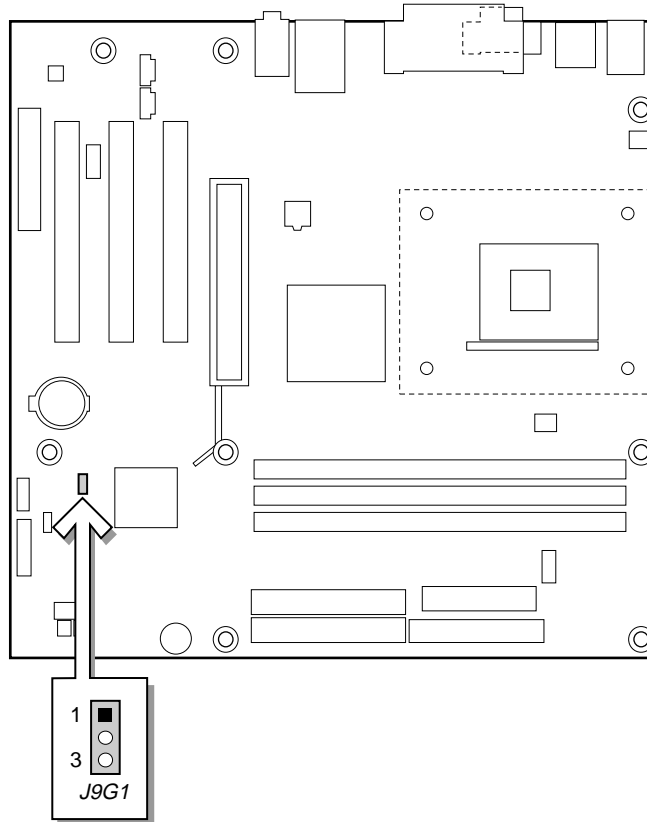

Always turn off the power and unplug the power cord from the computer before changing the jumper block settings. Moving the jumper with the power on may result in unreliable computer operation.



OM11996

The BIOS configuration jumper block determines the operating mode of the BIOS Setup Program and enables BIOS recovery in the event of a failed BIOS update. The following table describes the jumper block settings for the BIOS Setup configuration jumper.

BIOS Setup Configuration Jumper Block (J9G1) Settings

Jumper Position	Mode	Description
 1 3	Normal (default)	The BIOS uses the current configuration and passwords for booting.
 1 3	Configure	After the Power-On Self-Test (POST) runs, the BIOS displays the Maintenance Menu. Use this menu to clear passwords.
 1 3	Recovery	The BIOS recovers data from a recovery diskette in the event of a failed BIOS update. To update or recover the BIOS, see the instructions in the Intel Desktop Boards D845HV and D45WN Product Guide on the Intel Express Installer CD-ROM.

For a complete list of BIOS Setup settings, see:

- The *Intel Desktop Boards D845HV and D845WN Product Guide* on the Intel Express Installer CD-ROM
- The Intel World Wide Web Site at <http://support.intel.com/support/motherboards/desktop/>

Intel® 桌面主板

D845HV 和 D845WN

快速参考指南

本指南供已具备安装和配置桌面主板经验的合格技术人员使用。

开始之前

警告和注意事项	3
安全和规范通告	3

桌面主板元件

D845HV 桌面主板元件	4
D845WN 桌面主板元件	6

支持的元件	8
-------------	---

安装步骤

1 安装 I/O 防护板	9
2 安装桌面主板	10
3 安装处理器风扇散热器座	12
4 安装处理器	14
5 安装处理器风扇散热器	14
6 安装内存模块	15
7 安装 AGP 卡固定架	17
8 安装 AGP 卡	19
9 连接风扇	20
10 安装 IDE 驱动器	21

设置 BIOS 配置跳线块	22
---------------------	----

Intel® Express Installer (快速安装程序) 光盘内容

- 产品保修书
- Intel Express Installer (快速安装程序)
- Intel® 桌面主板 D845HV 和 D845WN 产品指南
- 软件实用程序和驱动程序
- 软件许可证协议
- 自述文件

获取帮助

您可从以下 Intel 万维网站点查看或下载产品的支持信息：

<http://support.intel.com/support/motherboards/desktop>

万维网站点上的文档包括：

- Intel® 桌面主板 D845HV/D845WN 产品技术规格
- Intel® 桌面主板 D845HV/D845WN 产品技术规格更新

如果在万维网上未找到您所需的信息，请联系您的经销商。Intel 万维网站点上还列出了 Intel 客户支持的电话号码及收费标准（若需收费）。

Intel 公司 (Intel) 就本文档不作任何形式的担保，包括但不限于就适销性和特定用途适用性作暗示担保。Intel 对本资料中可能出现的任何错误不承担任何责任。Intel 不承诺将对本文档中的信息进行更新或保证其内容与以后的最新情况相符合。本文档中的任何内容，未经 Intel 公司事先书面许可，不得以任何形式或途径进行复制或制作副本。

只要按照所提供文档中的说明使用 Intel® 产品，此产品具备“2000 年正常运行” (Year 2000 Capable) 特性。安装后，此产品能够精确地存储、显示、处理、提供和/或接收日期数据，包括闰年在内的介于二十世纪和二十一世纪之间的日期数据，均能精确读取和写入。但与此产品配合使用的所有其它技术应能够与此产品正确地交换日期数据。

Intel 和 Pentium 是 Intel Corporation 或其子公司在美国及其他国家的商标和注册商标。

† 本文档中提及的其它品牌和名称属于其相应所有者的财产。

Copyright © 2001, Intel Corporation. 保留所有权利。

开始之前

警告和注意事项



警告

在连接或断开主板电缆、安装或拆卸任何主板元件之前，请将主板的电源接头从交流电插座上拔下。否则，可能会导致人身伤害或损坏设备。即使在关闭前面板电源按钮以后，桌面主板上的某些电路仍可能继续带电。



注意

静电释放 (ESD) 可能会损坏桌面主板的元件。请在配备 ESD 控制装置的工作台上安装主板。如果没有 ESD 工作台可用，请在接触主板之前佩戴防静电腕带或触摸防静电包装的表面。

安全和规范通告：

有关此产品符合的所有标准及规范的声明、产品认证标识、安全与电磁兼容性 (EMC) 标准以及所符合的各种规章等详情，请参阅《Intel 桌面主板 D845HV 和 D845WN 产品指南》。

提供的更换电池警告标签：请将此标签贴在机箱内靠近电池且容易看见的位置，注意不要贴在母板上。

设计应用领域：此产品经过评估测试，认定为信息技术设备 (I.T.E.)，可用于家用和商用个人计算机中。此产品在其它应用领域或应用环境的适用性，有待进一步鉴定。



注释

本手册的所有图示均为 D845HV 母板的布局，另行注明者除外。

桌面主板元件

D845HV 桌面主板元件

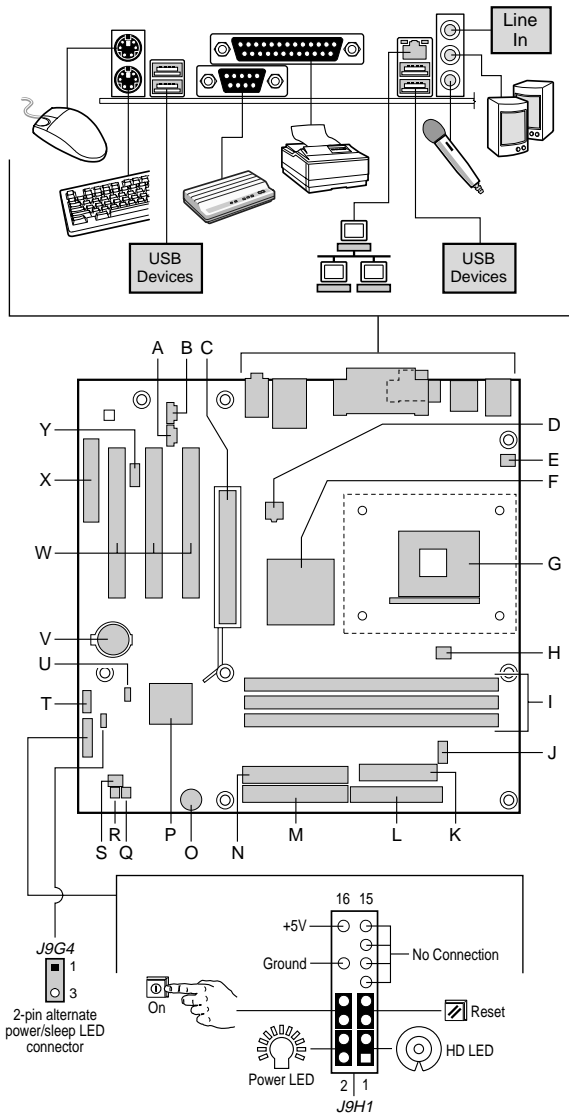

OM11984

待续

D845HV 桌面主板元件 (续)

A CD-ROM 连接器 (ATAPI)	N 次 IDE 连接器
B 辅助线路输入连接器 (ATAPI)	O 扬声器
C AGP 连接器 (仅 1.5 V)	P Intel® 82801BA I/O 控制器枢纽 (ICH2)
D 12 V 处理器内核电压连接器	Q SCSI 硬盘驱动器活动 LED 指示灯连接器
E 机箱背面风扇连接器 (转速计输入)	R 机箱开启连接器
F Intel® 82845 内存控制器 枢纽 (MCH)	S 机箱前面风扇连接器
G 处理器插座	T 前面板 USB 连接器
H 处理器风扇连接器 (转速计输入)	U BIOS 配置跳线块
I DIMM 插座	V 电池
J 串行端口 B 连接器	W PCI 总线附加卡连接器
K 电源连接器	X 通信和联网提升器 (CNR) 连接器 (可选)
L 软盘驱动器连接器	Y 前面板音频连接器
M 主 IDE 连接器	



注意

许多中间板和前面板的连接器为计算机机箱内的设备 (如风扇和内部外围设备) 提供工作电压 (如, +5 VDC 和 +12 VDC)。这些连接器不具备过载保护。请不要使用这些连接器为计算机机箱外的设备提供电源。由外部设备产生的电源加载故障可能会损坏计算机、互连的电缆和外部设备本身。

D845WN 桌面主板元件

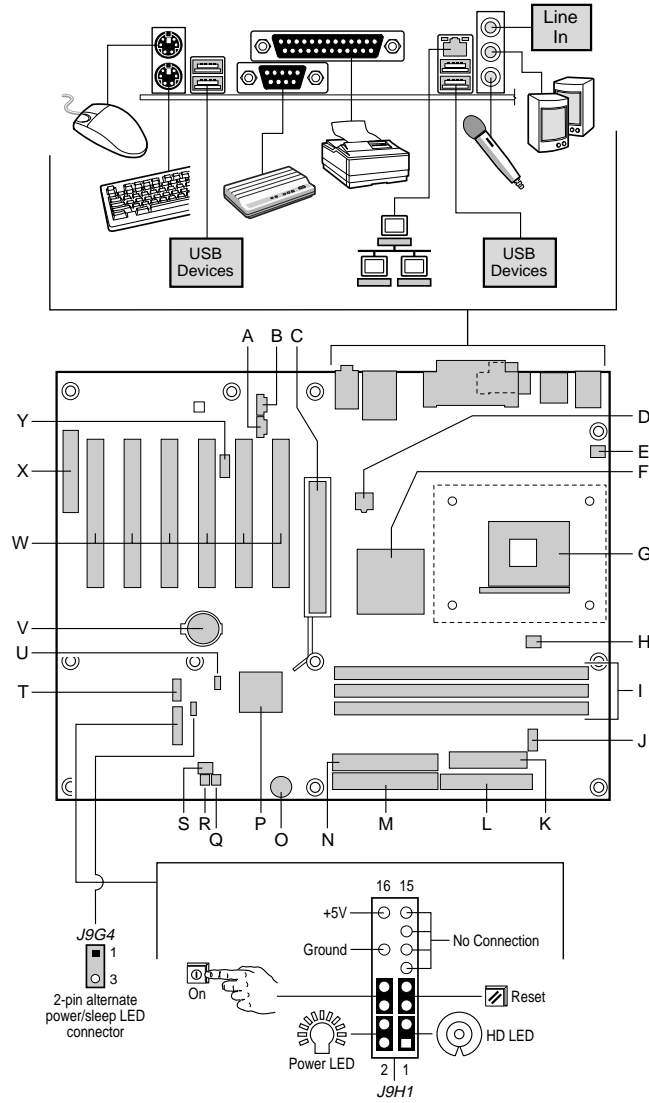

OM12040

D845WN 桌面主板元件（续）

A CD-ROM 连接器 (ATAPI)	N 次 IDE 连接器
B 辅助线路输入连接器 (ATAPI)	O 扬声器
C AGP 连接器（仅 1.5 V）	P Intel 82801BA I/O 控制器枢纽 (ICH2)
D 12 V 处理器内核电压连接器	Q SCSI 硬盘驱动器活动 LED 指示灯连接器
E 机箱背面风扇连接器 （转速计输入）	R 机箱开启连接器
F Intel 82845 内存控制器 枢纽 (MCH)	S 机箱前面风扇连接器
G 处理器插座	T 前面板 USB 连接器
H 处理器风扇连接器 （转速计输入）	U BIOS 配置跳线块
I DIMM 插座	V 电池
J 串行端口 B 连接器	W PCI 总线附加卡连接器
K 电源连接器	X 通信和联网提升器 (CNR) 连接器（可选）
L 软盘驱动器连接器	Y 前面板音频连接器
M 主 IDE 连接器	



注意

许多中间板和前面板的连接器为计算机机箱内的设备（如风扇和内部外围设备）提供工作电压（如，+5 VDC 和 +12 VDC）。这些连接器不具备过载保护。请不要使用这些连接器为计算机机箱外的设备提供电源。由外部设备产生的电源加载故障可能会损坏计算机、互连的电缆和外部设备本身。

支持的元件

处理器



注意

若未使用 ATX12V 电源系统，或未为 D845HV 或 D845WN 主板连接附加电源系统引线，可能会对桌面母板和/或电源系统造成损害。

有关 ATX12V 电源系统的详情，请参阅 Intel Express Installer（快速安装程序）光盘上的《Intel 桌面主板 D845HV 和 D845WN 产品指南》。

本主板支持下列处理器：

类型	频率标志	系统总线频率
Intel® Pentium® 4 处理器，采用 mPGA-478 引脚封装	1.4 GHz, 1.5 GHz, 1.6 GHz, 1.7 GHz 和 1.8 GHz	400 MHz

有关 D845HV 和 D845WN 主板所支持处理器的最新信息，请访问以下 Intel 万维网站：

<http://support.intel.com/support/motherboards/desktop>

内存模块要求

本主板支持以下定义的系统内存：

- 带有镀金触点的 168 针 SDRAM 双列直插式内存模块 (DIMM)
- 不与其它类型混合安装的 PC133 SDRAM
- 64 Mbit、128 Mbit 和 256 Mbit 内存模块，采用以下配置：
 - 32 MB 至 384 MB（64 Mbit 内存模块）
 - 最高达 768 MB（128 Mbit 内存模块）
 - 最高达 1.5 GB（256 Mbit 内存模块）



注释

根据 D845HV 和 D845WN 桌面主板的设计，可支持安装 512 Mbit 的 DIMM 内存模块，最高内存容量可达 3 GB，但此技术在这些主板上的应用尚未得到验证。有关最新测试通过的内存模块配置的列表，请访问以下 Intel 万维网站：

<http://support.intel.com/support/motherboards/desktop>

- 无缓冲和无寄存单面或双面 DIMM
- 串行设备检测 (SPD) 内存
- 非 ECC（错误校正）和 ECC DIMM
- 仅支持 3.3 V 内存

☞ 注释

本桌面主板使用的所有内存元件和 DIMM 内存模块必须符合 PC SDRAM 规格。包括 PC SDRAM 规格（内存元件规格）和 PC 无缓冲 DIMM 规格。欲查看或下载这些规格，请访问以下 Intel 万维网站点：

<http://www.intel.com/technology/memory/pcsdram/>

有关支持这些内存要求的产品供应商详情，请访问以下 Intel 万维网站点中的 D845HV 和 D845WN 链接：

<http://support.intel.com/support/motherboards/desktop/>

安装步骤

1 安装 I/O 防护板

随主板提供了一块 I/O 防护板。在机箱中安装此防护板后，可阻挡无线电射频向外传播，是获得产品辐射 (EMI) 合格认证的必要条件。同时此防护板保护内部元件免受灰尘及异物侵害，并可促进空气在机箱内正确流通。

在机箱中安装主板之前，应先安装 I/O 防护板。如下图所示，将防护板放入机箱中。沿箭头所指方向推压防护板，使其紧固到位。如果配备的防护板不适合机箱的大小，请从机箱供应商处取得大小合适的防护板。

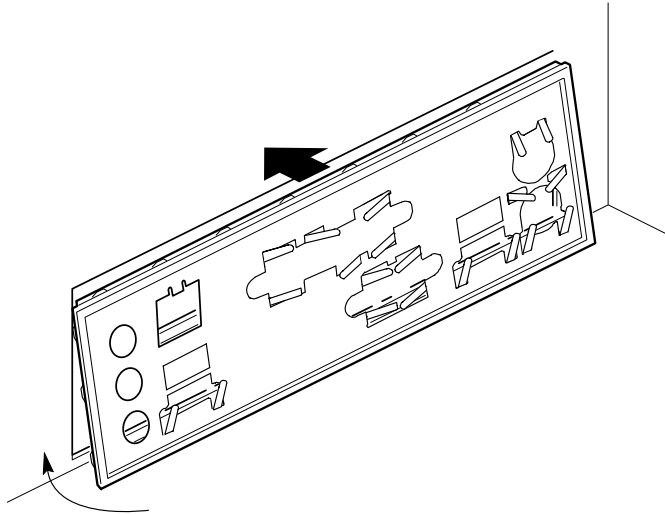

OM11543

2 安装桌面主板



注意

若未使用 ATX12V 系统电源，或未为 D845HV 或 D845WN 主板连接附加电源系统引线，可能会对桌面主板和/或电源系统造成损害。

有关 ATX12V 电源系统的详情，请参阅 Intel Express Installer（快速安装程序）光盘上的《Intel 桌面主板 D845HV 和 D845WN 产品指南》。

有关安装和拆卸主板的具体说明，请参阅机箱手册。使用螺丝将主板固定在机箱的支撑立柱上。

下图显示了 D845HV 主板上的 8 个固定孔位。

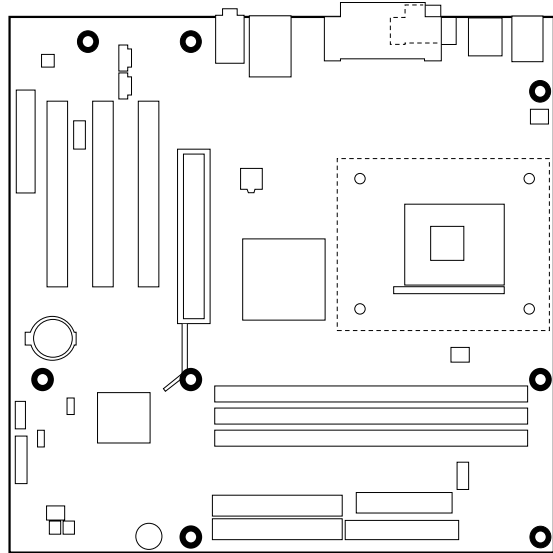

OM11982

D845HV 母板的固定孔位

下图显示了 D845WN 主板上的 11 个固定孔位。

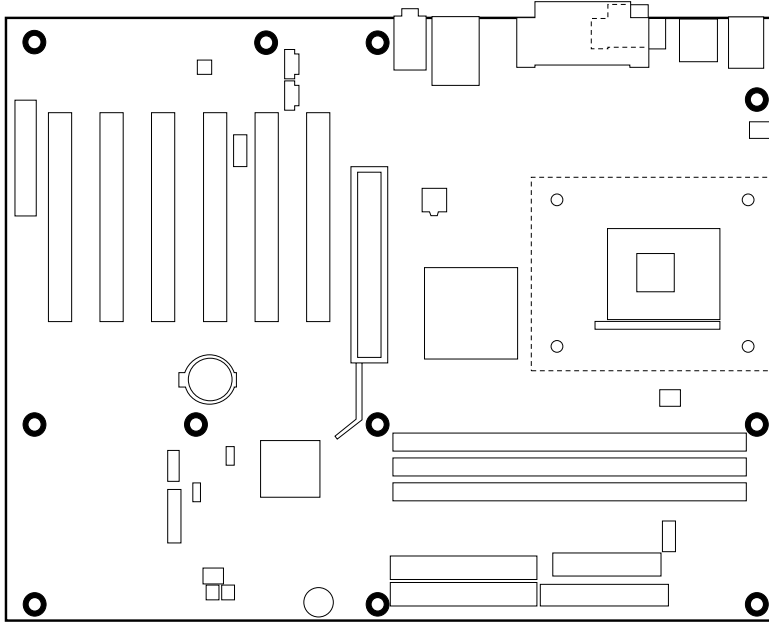

OM12080

D845WN 母板的固定孔位

3 安装处理器风扇散热器座

➡ 注释

以下组装操作，应在机箱中安装并固定桌面 motherboard 后执行。

随主板提供了一个处理器风扇散热器座。请按以下步骤将风扇散热器座安装到母板上。

1. 请遵守“开始之前”中说明的注意事项（参阅第 3 页）。
2. 处理器风扇散热器座用 4 颗高顶钉固定到母板上。下图显示了处理器风扇散热器座的固定孔位。

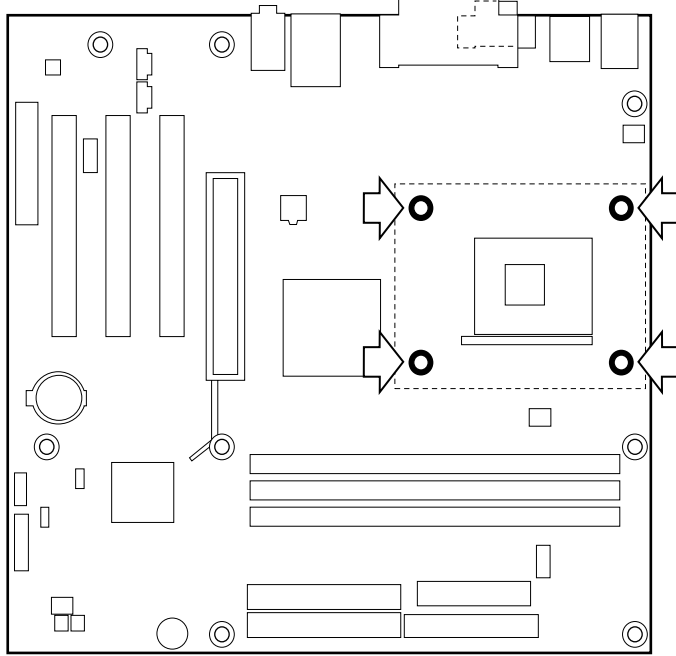

OM11983

3. 将处理器风扇散热器 RM 座上的 4 个夹固销 (B) 与桌面母板上对应的孔位 (C) 对齐。轻缓地向下按压散热器座，直到其四个角都卡固到位。检查并确保 4 个夹固销都已完全卡固到位，然后逐个按下 4 个高顶钉 (A)，将散热器座锁固到母板上。

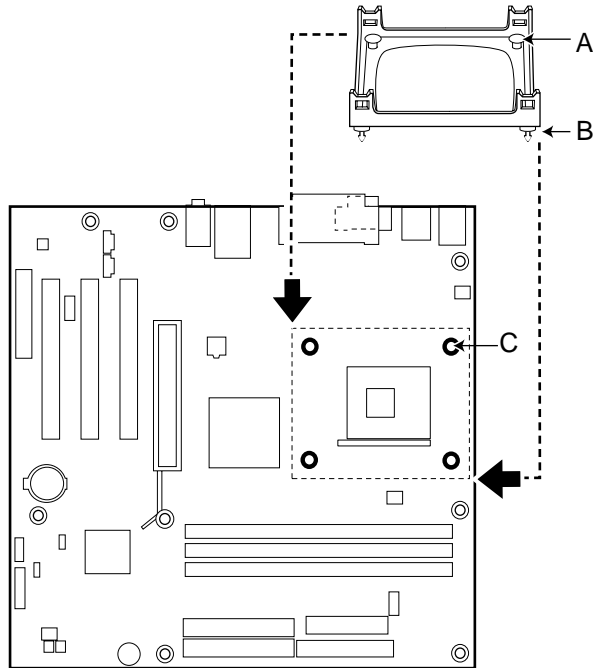

OM12096

4 安装处理器

1. 请遵守“开始之前”中说明的注意事项（参阅第 3 页）。
2. 将处理器插座的拉杆完全抬起。
3. 让处理器上有三角标志 (A) 的一角与插座上连接拉杆的一角对齐，将处理器插入插座中。
4. 将拉杆按回原位，使其完全闭合。

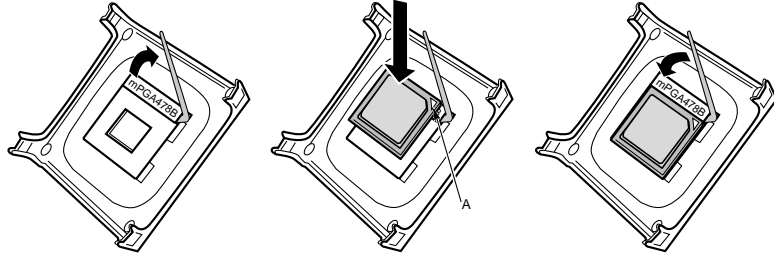

OM12078

5 安装处理器风扇散热器

有关安装处理器风扇散热器的指导，请参阅产品包装盒中附送的处理器手册，或访问以下 Intel 万维网站点：

<http://support.intel.com/support/motherboards/desktop>

6 安装内存模块



注意

在安装 AGP 视频卡之前，请先将内存安装到 DIMM 插座上，以避免内存固定架对您的操作造成阻碍。

在 D845HV 和 D845WN 母板上，要求安装 DIMM（双列直插式内存模块）。三个 DIMM 插座依次排列为 Bank 0、Bank 1 和 Bank 2，如下图所示。如果只安装一条 DIMM，将它安装在 Bank 0 中。如果要安装两条 DIMM，则安装在 Bank 0 和 Bank 1 中。

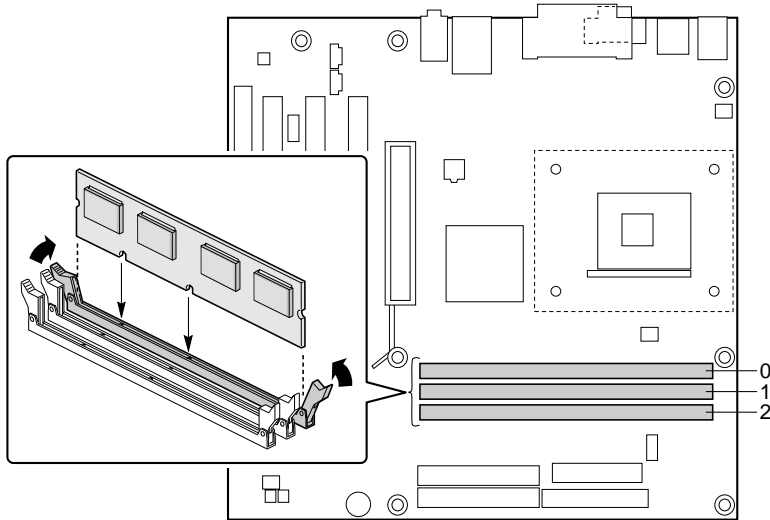

OM11986

要安装 DIMM（双列直插式内存模块），请按以下步骤操作：

1. 请遵守“开始之前”中说明的注意事项（参阅第 3 页）。
2. 关闭所有与计算机连接的外围设备。关闭计算机电源，并拔下计算机电源线。
3. 打开计算机机箱盖，找到 DIMM 插座。
4. 卸下 AGP 视频卡（如果此卡使您打开和关闭 DIMM 卡固销子比较困难）。
5. 用手握住 DIMM 的边缘，将其从防静电袋中取出。
6. 确保插座两端的卡固销子已推到张开状态（如上图所示）。
7. 将 DIMM 放置在插座上。将 DIMM 底部边缘的两个小凹口与插座上的卡固销子对齐。
8. 将 DIMM 的底边插入插座。
9. 插入 DIMM 期间，按住 DIMM 的顶边向下推压，直到卡固销子将其卡固到位。确保销子已牢牢夹紧。
10. 若在安装 DIMM 前拆卸了 AGP 视频卡，重新将此卡安装到位。
11. 重新盖好计算机机箱盖。

7 安装 AGP 卡固定架



注意

只有在使用带固定槽口 (A) (如下图所示) 的 AGP 视频卡时, 才需要安装固定架 (RM)。无槽口的卡若使用固定架可能会引起不良操作。有关拆卸固定架的指导, 请参阅 Intel Express Installer (快速安装程序) 光盘上的《Intel 桌面主板 D845HV 和 D845WN 产品指南》。



注释

并非所有的 D850HV 和 D850WN 桌面主板都配备有 AGP 卡固定架。如果您的桌面主板包装盒中未包括 AGP 卡固定架, 请参阅第 19 页“安装 AGP 卡”一节的说明。

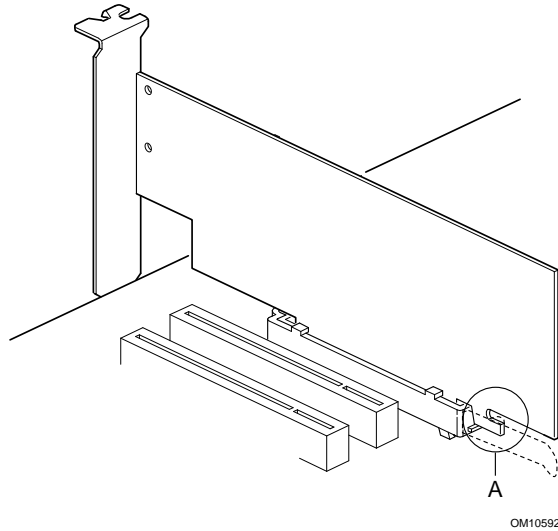

固定架包围在桌面母板上 AGP 卡插槽的周围，从而使安装到位的卡增加稳定性。将母板放置在一个平坦而且有稳固支持的平面上（元件面向上）。按照以下步骤将固定架 (RM) (A) 连接到 AGP 连接器 (B) 上：

1. 请遵守“开始之前”中说明的注意事项（参阅第 3 页）。
2. 如下图所示，在桌面母板上找到 AGP 连接器的位置。请注意，桌面母板上的丝网印刷线 (C) 表示固定架上控制杆 (D) 的最终位置。

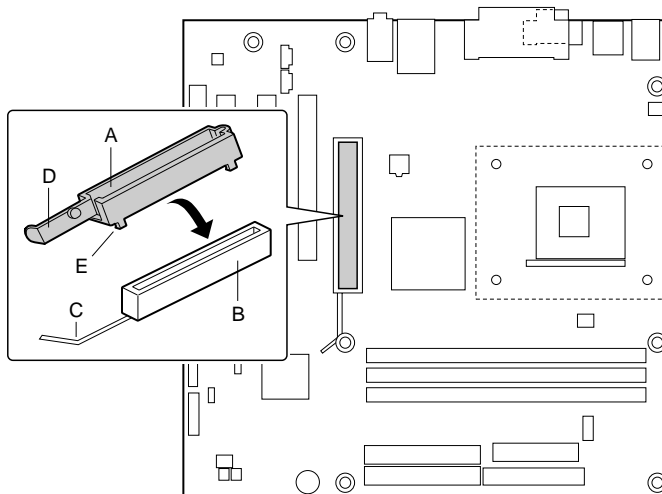

OM11980

3. 如下图所示，将固定架 (RM) 放在 AGP 连接器上。

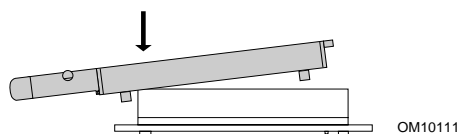

OM10111

4. 沿箭头方向推压 RM 的控制杆末端，直到最后边的两个小突出点 (E) 卡入 AGP 连接器的末端。

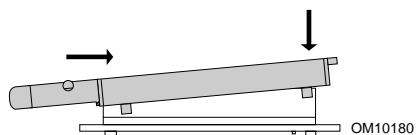

OM10180

5. 将 RM 活动的一端对准 AGP 连接器的另一端，并沿 RM 两端均匀地向下推压，直到四个小突出点全部卡入 AGP 连接器之下。不可用力过度，以免损坏母板。



8 安装 AGP 卡

➡ 注释

D845HV 和 D845WN 桌面母板只与 1.5 V AGP 卡兼容。

要安装带有固定槽口的 AGP 卡，请按以下步骤操作。

1. 请遵守“开始之前”中说明的注意事项（参阅第 3 页）。
2. 将 AGP 卡放入 AGP 连接器。
3. 向下推压卡的边缘，直到它完全卡入连接器，使卡的固定槽口完全卡扣啮合于固定架的下方。
4. 用螺丝将卡的金属支架固定到机箱的背面板上。

9 连接风扇

下图显示了风扇连接器的位置。将处理器风扇散热器电缆连接到主板上的处理器风扇连接器上。将机箱风扇电缆连接到主板上、如下图所示的连接

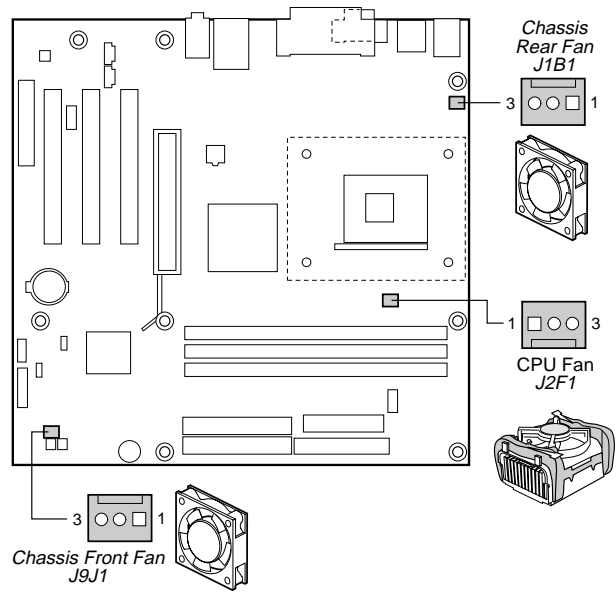

OM11985

10 安装 IDE 驱动器

Intel® 桌面母板的包装中包括两条 IDE 电缆。每条电缆可将两个驱动器连接到桌面母板上。40 触点电缆支持 Ultra DMA-33 传输协议；40 触点 80 芯电缆支持 ATA-66 和 ATA-100 传输协议，并向后兼容使用更慢速 IDE 传输协议的驱动器。

只有按下图所示的方向插接电缆，电缆才能正常工作。要使电缆发挥功能：

1. 请遵守“开始之前”中说明的注意事项（参阅第 3 页）。
2. 将电缆带有单连接器 (A) 的一端连接到桌面母板上。
3. 将电缆带有相邻双连接器 (B) 的一端连接到驱动器上。

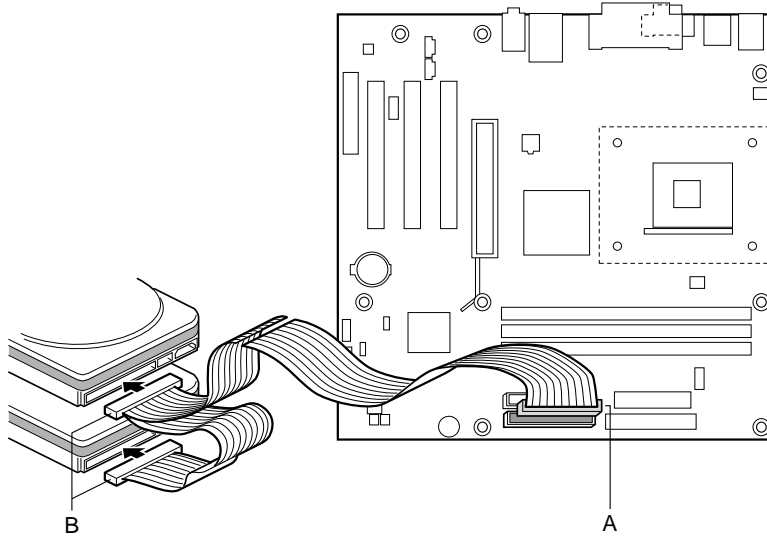

OM11988

设置 BIOS 配置跳线块



注意

更改跳线块设置之前，必须关闭计算机电源，并从计算机上拔下电源线。
若在计算机处于通电状态下调整跳线，可能导致计算机运行不稳定。

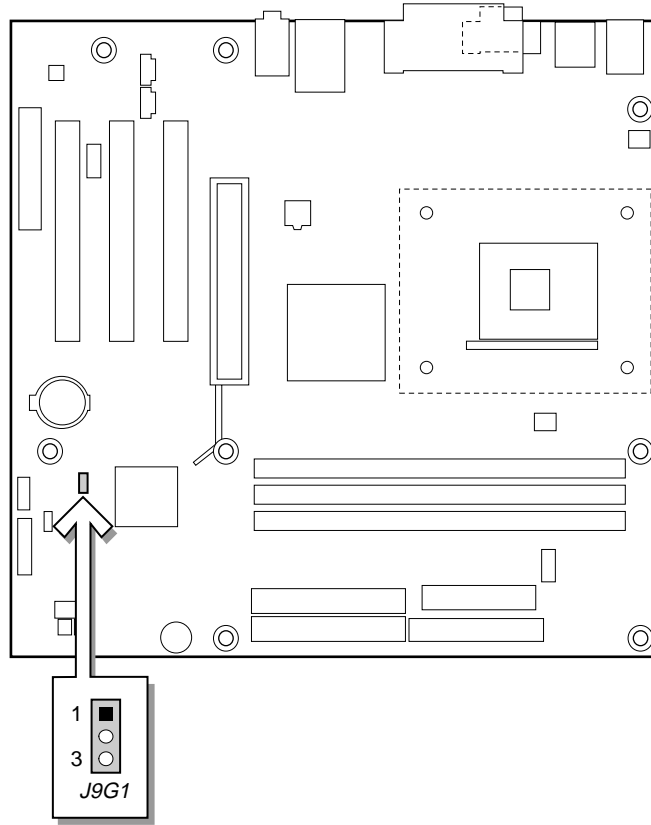

OM11996

BIOS 配置跳线块决定 BIOS Setup（设置）程序的运行模式，并可在更新 BIOS 失败时恢复原来的 BIOS 设置。下表列示了 BIOS Setup（设置）程序不同配置的跳线设置。

BIOS Setup 程序配置跳线块 (J9G1) 的设置

跳线位置	模式	描述
 1 3	正常（默认）	BIOS 使用当前配置和口令来启动系统。
 1 3	配置	开机自检 (POST) 运行后，BIOS 显示 Maintenance（维护）菜单。通过此菜单可清除口令。
 1 3	恢复	如果更新 BIOS 失败，BIOS 将从一张恢复软盘中恢复原来的 BIOS 设置数据。有关更新或恢复 BIOS 的指导，请参阅 Intel Express Installer（快速安装程序）光盘上的《Intel 桌面主板 D845HV 和 D845WN 产品指南》。

要查阅 BIOS Setup 程序各项设置的完整列表：

- 请参阅 Intel Express Installer（快速安装程序）光盘上的《Intel 桌面主板 D845HV 和 D845WN 产品指南》。
- 请访问以下 Intel 万维网站点：
<http://support.intel.com/support/motherboards/desktop/>

