



Intel® Desktop Board D865GBF Specification Update

Release Date: November 2004

Order Number: C41597-013

The Intel® Desktop Board D865GBF may contain design defects or errors known as errata, which may cause the product to deviate from published specifications. Current characterized errata are documented in this Specification Update.

INFORMATION IN THIS DOCUMENT IS PROVIDED IN CONNECTION WITH INTEL® PRODUCTS. NO LICENSE, EXPRESS OR IMPLIED, BY ESTOPPEL OR OTHERWISE, TO ANY INTELLECTUAL PROPERTY RIGHTS IS GRANTED BY THIS DOCUMENT. EXCEPT AS PROVIDED IN INTEL'S TERMS AND CONDITIONS OF SALE FOR SUCH PRODUCTS, INTEL ASSUMES NO LIABILITY WHATSOEVER, AND INTEL DISCLAIMS ANY EXPRESS OR IMPLIED WARRANTY, RELATING TO SALE AND/OR USE OF INTEL PRODUCTS INCLUDING LIABILITY OR WARRANTIES RELATING TO FITNESS FOR A PARTICULAR PURPOSE, MERCHANTABILITY, OR INFRINGEMENT OF ANY PATENT, COPYRIGHT OR OTHER INTELLECTUAL PROPERTY RIGHT. INTEL PRODUCTS ARE NOT INTENDED FOR USE IN MEDICAL, LIFE SAVING, LIFE SUSTAINING APPLICATIONS.

Intel may make changes to specifications and product descriptions at any time, without notice.

Designers must not rely on the absence or characteristics of any features or instructions marked "reserved" or "undefined". Intel reserves these for future definition and shall have no responsibility whatsoever for conflicts or incompatibilities arising from future changes to them.

The Intel® desktop board D865GBF may contain design defects or errors known as errata which may cause the product to deviate from published specifications. Current characterized errata are available on request.

Contact your local Intel sales office or your distributor to obtain the latest specifications before placing your product order.

Copies of documents which have an ordering number and are referenced in this document, or other Intel literature, may be obtained from:

Intel Corporation
P.O. Box 5937
Denver, CO 80217-9808

or call in North America 1-800-548-4725, Europe 44-0-1793-431-155, France 44-0-1793-421-777,
Germany 44-0-1793-421-333, other Countries 708-296-9333

Intel, Pentium, Celeron, and the Intel logo are trademarks or registered trademarks of Intel Corporation or its subsidiaries in the United States and other countries.

* Other names and brands may be claimed as the property of others.

Copyright © 2003, 2004 Intel Corporation.

CONTENTS

REVISION HISTORY	v
PREFACE	vi
Specification Update for the Intel® Desktop Board D865GBF	
GENERAL INFORMATION	3
SPECIFICATION CHANGES	8
ERRATA	14
SPECIFICATION CLARIFICATIONS	18
DOCUMENTATION CHANGES	27



REVISION HISTORY

Date of Revision	Version	Description
June 2003	-001	This document is the first Specification Update for the Intel® Desktop Board D865GBF. Added Errata 1, 2 and Specification Clarifications 1, 2.
July 2003	-002	Added Specification Change 1 and Specification Clarification 3.
August 2003	-003	Updated Erratum 2.
September 2003	-004	Added Erratum 3.
October 2003	-005	Added Erratum 4.
November 2003	-006	Added Specification Change 2, Erratum 5, Specification Clarification 3 and Documentation Change 1.
January 2004	-007	Corrected Specification Change 1. Added Specification Changes 3, 4. Added Errata 6-11. Added Specification Clarifications 5, 6. Added Documentation Changes 2, 3.
March 2004	-008	Added Specification Change 5.
April 2004	-009	Added Erratum 12.
May 2004	-010	Updated Erratum 12. Added Specification Clarifications 7, 8.
June 2004	-011	Updated Specification Clarifications 3 and 8.
July 2004	-012	Added Erratum 13.
November 2004	-013	Added Erratum 14.

PREFACE

This document is an update to the specifications contained in the *Intel® Desktop Board D865GBF/D865GLC Technical Product Specification* (Order number C32634). It is intended for hardware system manufacturers and software developers of applications, operating systems, or tools. It will contain Specification Changes, Errata, Specification Clarifications, and Documentation Changes.

Refer to the *Intel® Pentium® 4 Processor Specification Update* (Order number 249199) for specification updates concerning the Intel Pentium 4 processor and that may apply to the desktop board D865GBF. Unless otherwise noted in this document, it should be assumed that any processor errata for a given stepping are applicable to the Altered Assembly (AA) revision(s) associated with that stepping.

Refer to the *Intel® 865G/865GV Chipset Specification Update* (Order Number 252515) for specification updates concerning the 82865G GMCH Controller and that may apply to the desktop board D865GBF. Unless otherwise noted in this document, it should be assumed that any MCH errata for a given stepping are applicable to the Altered Assembly (AA) revision(s) associated with that stepping.

Refer to the *Intel® 82801EB I/O Controller Hub 5 (ICH5) Specification Update* (Order Number 252517) for specification updates concerning the 82801ER I/O Controller Hub and that may apply to the desktop board D865GBF. Unless otherwise noted in this document, it should be assumed that any ICH 5 errata for a given stepping are applicable to the Altered Assembly (AA) revision(s) associated with that stepping.

Nomenclature

Specification Changes are modifications to the current published specifications. These changes will be incorporated in the next release of the specifications.

Errata are design defects or errors. Characterized errata may cause the desktop board D865GBF's behavior to deviate from published specifications. Hardware and software designed to be used with any given Altered Assembly (AA) and BIOS revision level must assume that all errata documented for that AA and BIOS revision level are present on all desktop boards.

Specification Clarifications describe a specification in greater detail or further highlight a specification's impact to a complex design situation. These clarifications will be incorporated in the next release of the specifications.

Documentation Changes include typos, errors, or omissions from the current published specifications. These changes will be incorporated in the next release of the specifications.

**Specification Update for the
Intel[®] Desktop Board D865GBF**

GENERAL INFORMATION

Basic Desktop Board D865GBF Identification Information

AA Revision	BIOS Revision	Notes
C25827-401	BF86510A.86A.0024.P03	1-5
C25827-402	BF86510A.86A.0033.P06	1-5
C25827-403	BF86510A.86A.0036.P07	1-5
C25827-404	BF86510A.86A.0038.P08	1-5
C25827-405	BF86510A.86A.0043.P09	1-5
C25827-406	BF86510A.86A.0046.P10	1-5
C25827-407	BF86510A.86A.0053.P13	1-5
C25827-408	BF86510A.86A.0060.P16	1-5
C25827-409	BF86510A.86A.0063.P18	1-5
C25840-401	BF86510A.86A.0024.P03	1-5
C25840-402	BF86510A.86A.0033.P06	1-5
C25840-403	BF86510A.86A.0036.P07	1-5
C25840-404	BF86510A.86A.0038.P08	1-5
C25840-405	BF86510A.86A.0046.P10	1-5
C25840-406	BF86510A.86A.0053.P13	1-5
C25840-407	BF86510A.86A.0060.P16	1-5
C25840-408	BF86510A.86A.0063.P18	1-5
C25843-401	BF86510A.86A.0024.P03	1-5
C25843-402	BF86510A.86A.0033.P06	1-5
C25843-403	BF86510A.86A.0036.P07	1-5
C25843-404	BF86510A.86A.0036.P07	1-5
C25843-405	BF86510A.86A.0043.P09	1-5
C25843-406	BF86510A.86A.0046.P10	1-5
C25843-407	BF86510A.86A.0053.P13	1-5
C25843-408	BF86510A.86A.0060.P16	1-5
C25843-409	BF86510A.86A.0063.P18	1-5
C28140-401	BF86510A.86A.0024.P03	1-5
C28140-402	BF86510A.86A.0033.P06	1-5
C28140-402	BF86510A.86A.0036.P07	1-5
C28140-403	BF86510A.86A.0038.P08	1-5

Basic Desktop Board D865GBF Identification Information (cont)

AA Revision	BIOS Revision	Notes
C28140-404	BF86510A.86A.0038.P08	1-5
C28140-405	BF86510A.86A.0046.P10	1-5
C28140-406	BF86510A.86A.0053.P13	1-5
C28140-407	BF86510A.86A.0060.P16	1-5
C28140-408	BF86510A.86A.0063.P18	1-5
C28142-401	BF86510A.86A.0024.P03	1-5
C28142-402	BF86510A.86A.0033.P06	1-5
C28142-402	BF86510A.86A.0036.P07	1-5
C28142-403	BF86510A.86A.0036.P07	1-5
C28142-404	BF86510A.86A.0038.P08	1-5
C28142-405	BF86510A.86A.0043.P09	1-5
C28142-406	BF86510A.86A.0046.P10	1-5
C28142-407	BF86510A.86A.0053.P13	1-5
C28142-408	BF86510A.86A.0056.P14	1-5
C28142-409	BF86510A.86A.0060.P16	1-5
C28142-410	BF86510A.86A.0063.P18	1-5
C28144-402	BF86510A.86A.0024.P03	1-5
C28144-403	BF86510A.86A.0033.P06	1-5
C28144-403	BF86510A.86A.0036.P07	1-5
C28144-404	BF86510A.86A.0036.P07	1-5
C28144-405	BF86510A.86A0038.P08	1-5
C28144-406	BF86510A.86A0046.P10	1-5
C28144-407	BF86510A.86A.0053.P13	1-5
C28144-408	BF86510A.86A.0056.P14	1-5
C28144-409	BF86510A.86A.0060.P16	1-5
C28144-410	BF86510A.86A.0060.P16	1-5

NOTES:

1. The AA number is found on a small label on the component side of the board.
2. The 82865G Chipset kit used on this AA revision consists of two components as follows:

Device	Stepping	S-Spec Numbers
82865G GMCH	A2	SL743
82801EB ICH5	A2 A3	SL6TN SL73Z



3. Refer to the *Intel® Pentium® 4 Processor Specification Update* (Order Number 249199) for errata related to the Pentium 4 processor and that may apply to the desktop board D865GBF.
4. Refer to the *Intel® 865/865GV Chipset Specification Update* (Order Number 252515) for errata related to the 82865G GMCH that may apply to the desktop board D865GBF.
5. Refer to the *Intel® 82801EB I/O Controller Hub 5 (ICH5) Specification Update* (Order Number 252517) for errata related to the 82801ER I/O Controller Hub that may apply to the desktop board D865GBF.

Summary Table of Changes

The following table indicates the Specification Changes, Errata, Specification Clarifications, or Documentation Changes that apply to the desktop board D865GBF. Intel intends to fix some of the errata in a future revision of the desktop board, and to account for the other outstanding issues through documentation or specification changes as noted. This table uses the following notations:

CODES USED IN SUMMARY TABLE

Doc:	Document change or update that will be implemented.
Plan Fix:	This erratum may be fixed in a future revision of the desktop board, driver, or BIOS.
Fixed:	This erratum has been previously fixed.
No Fix:	There are no plans to fix this erratum.
Shaded:	This erratum is either new or modified from the previous version of the document.

NO.	PLANS	SPECIFICATION CHANGES
1	Doc	Change to Section 4.3, Main Menu, BIOS Setup Program
2	Doc	Change to description of the SMBIOS specification listed in Table 4, Section 1.5
3	Doc	Change to description of the SMBIOS specification listed in Table 4, Section 1.5
4	Doc	Change to description of Section 2.11.1, DC Loading
5	Doc	Change to Thermal Considerations, Section 2.12
NO.	PLANS	ERRATA
1	No Fix	Audio driver creates a popping noise during operating system startup
2	Fix	Front panel audio connector signals routed incorrectly
3	Plan Fix	PCI slot 4 cannot be used with long PCI add-in cards
4	Plan Fix	Some UDMA 6 hard disk drives may not operate properly
5	Plan Fix	PXE Boot is inoperative when using some add-in AGP video cards that have 256 MB of onboard memory
6	Plan Fix	PCI slot 1 cannot be used with long PCI add-in cards
7	No Fix	Advance jack sense may not recognize devices connected to a front panel audio port
8	No Fix	Advance jack sense on boards with 6-channel audio will report "Microphone" for any device connected to the back panel microphone port (pink)
9	No Fix	Advance jack sense will not detect devices connected to the Center/LFE and Surround ports
10	No Fix	Advance jack sense may report amplified speakers as an array microphone when connected to the microphone port (pink)
11	No Fix	An additional reboot may be required after installing audio drivers for Microsoft Windows® 98SE or Windows ME
12	Plan Fix	System memory may be reduced in excess of the amount of AGP aperture size when 4GB of system memory are used

NO.	PLANS	ERRATA
13	Plan Fix	Some systems may hang if the mouse is moved when entering standby mode
14	Plan Fix	System may intermittently hang at POST code 75 with SATA hard disk drives attached
NO.	PLANS	SPECIFICATION CLARIFICATIONS
1	Doc	Add note that specifies Enhanced Mode IDE/Serial ATA requirements to Section 3.3.2, PCI IDE Support
2	Doc	Updates to the design specifications applicable to the desktop board D865GBF
3	Doc	Change to description of Table 28, Front Panel Audio Connector
4	Doc	Clarification of SMBus routing
5	Doc	Clarification of DDR voltage
6	Doc	Clarification of Section 2.11.1, DC Loading
7	Doc	Change to description of Section 2.11.3, Fan Connector Current Supply, Correction of processor and voltage regulator fan current
8	Doc	Change to description of Section 2.9.1, Front Panel Audio Connector/Jumper Block
NO.	PLANS	DOCUMENTATION CHANGES
1	Doc	Removal of Intel® branding from subtitle of Section 1.10.2
2	Doc	Change to description of 10/100 LAN LED states
3	Doc	Change to description of Gigabit LAN LED states

SPECIFICATION CHANGES

The Specification Changes listed in this section apply to the *Intel® Desktop Board D865GBF/D865GLC Technical Product Specification* (Order Number C32634). All Specification Changes will be incorporated into a future version of that specification.

1. Change to Section 4.3, Main Menu, BIOS Setup Program

Section 4.3, Main Menu of the BIOS setup program will change in its entirety as follows:

4.3 Main Menu

To access this menu, select Main on the menu bar at the top of the screen.

Maintenance	Main	Advanced	Security	Power	Boot	Exit
-------------	-------------	----------	----------	-------	------	------

Table 56 describes the Main menu. This menu reports processor, memory, and Desktop Management Interface (DMI) information and is for configuring the system date and system time.

Table 56. Main Menu

Feature	Options	Description
BIOS Version	No options	Displays the version of the BIOS.
Processor Type	No options	Displays processor type.
Processor Speed	No options	Displays processor speed.
System Bus Speed	No options	Displays the system bus speed.
System Memory Speed	No options	Displays the system memory speed.
Cache RAM	No options	Displays the size of second-level cache.
Total Memory	No options	Displays the total amount of RAM.
Memory Bank 0 Memory Bank 1	No options	Displays the amount and type of RAM in the memory banks.
Language	<ul style="list-style-type: none"> • English (default) • Español 	Selects the current default language used by the BIOS.
► Additional System Information	<ul style="list-style-type: none"> • No options 	Displays the system DMI Information.
System Time	Hour, minute, and second	Specifies the current time.
System Date	Day of week Month/day/year	Specifies the current date.

Note: BIOS revision BF86510A.86A.0036.P07 or later is needed to support the *Additional System Information* submenu.

2. **Change to Description of the SMBIOS Specification Listed in Table 4, Section 1.5**

Table 4, Section 1.5, SMBIOS specification will change as follows:

Table 4. Specifications

Reference Name	Specification Title	Version, Revision Date, and Ownership	The information is available from...
SMBIOS	<i>System Management BIOS</i>	Version 2.3.2, October 12, 2001, Distributed Management Taskforce, Inc (DMTF)	http://www.dmtf.org/standards/documents/SMBIOS/DSP0130.pdf

3. **Change to Description of the SMBIOS Specification Listed in Table 4, Section 1.5**

Table 4, Section 1.5, SMBIOS specification will change as follows:

Table 4. Specifications

Reference Name	Specification Title	Version, Revision Date, and Ownership	The information is available from...
SMBIOS	<i>System Management BIOS</i>	Version 2.3.4, December 6, 2002, Distributed Management Taskforce, Inc (DMTF)	http://www.dmtf.org/standards/documents/SMBIOS/DSP0134.pdf

4. **Change to Description of Section 2.11.1, DC Loading**

Table 43, Section 2.11.1, DC Loading, will change in its entirety as follows:

2.11.1 DC LOADING

Table 43 lists the DC loading characteristics of the board.

Table 43. DC Loading Characteristics

Mode	DC Power	DC Current at:				
		+3.3 V	+5 V	+12 V	-12 V	+5 VSB
Minimum loading	190.00 W	5.00 A	11.00 A	9.00 A	0.03 A	0.60 A
Maximum loading	310.00 W	11.00 A	15.00 A	15.00 A	0.10 A	1.38 A

5. Change to Thermal Considerations, Section 2.12

Section 2.12, Thermal Considerations will change in its entirety as follows:

2.12 Thermal Considerations



CAUTION

The use of an Intel® Pentium® 4 processor operating above 2.80 GHz with this Intel® desktop board requires the following:

- *A chassis with appropriate airflow to ensure proper cooling of the components on the board*
- *A processor fan heatsink that meets the thermal performance targets for Pentium 4 processors operating above 2.80 GHz*

The use of an Intel Pentium 4 processor with 1 MB of L2 cache on this Intel desktop board requires the following:

- *A chassis with a maximum internal ambient temperature of 38 Degrees Celsius*
- *A processor heatsink that provides omnidirectional airflow so that air is drawn across the processor voltage regulator area (item A in Figure 30). Figure 29a illustrates an omnidirectional airflow heatsink.*

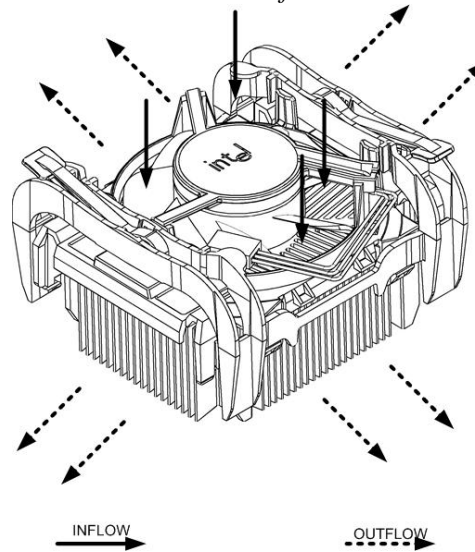

Figure 29a. Omnidirectional Airflow Heatsink

Failure to ensure appropriate airflow may result in reduced performance of both the processor and/or voltage regulator or, in some instances, damage to the desktop board. For a list of chassis that have been tested with Intel® desktop boards please refer to the following website:

<http://developer.intel.com/design/motherbd/cooling.htm>

All responsibility for determining the adequacy of any thermal or system design remains solely with the reader. Intel makes no warranties or representations that merely following the instructions presented in this document will result in a system with adequate thermal performance.

**CAUTION**

Ensure that the ambient temperature does not exceed the Desktop Board's maximum operating temperature. Failure to do so could cause components to exceed their maximum case temperature and malfunction. For information about the maximum operating temperature, see the environmental specifications in Section 2.14.

**CAUTION**

Ensure that proper airflow is maintained in the processor voltage regulator circuit. Failure to do so may result in damage to the voltage regulator circuit. The processor voltage regulator area (item A in Figure 30) can reach a temperature of up to 85 °C in an open chassis.

Figure 30 shows the locations of the localized high temperature zones.

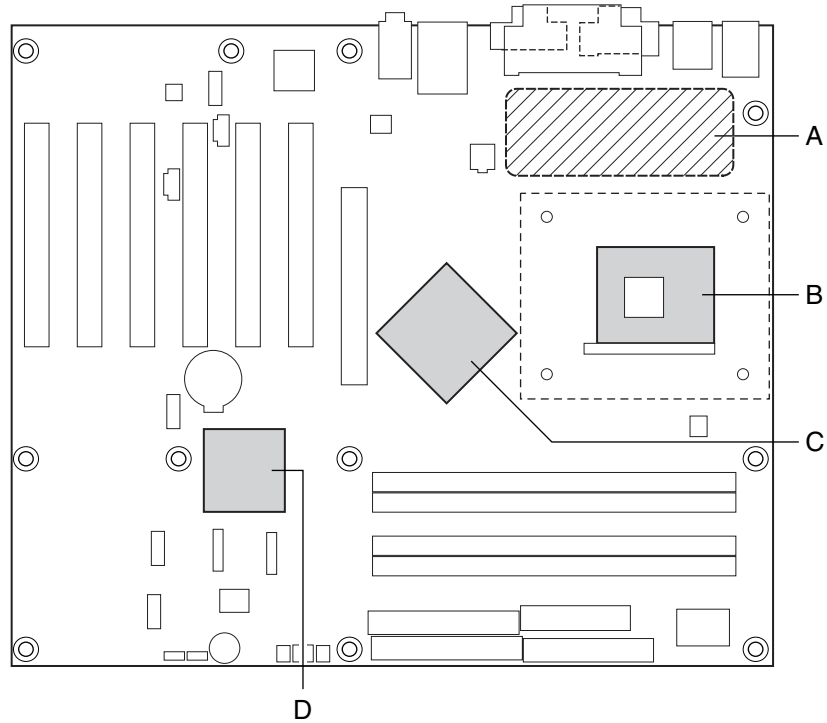

OM15925

Item	Description
A	Processor voltage regulator area
B	Processor
C	Intel® 82865G GMCH
D	Intel® 82801EB ICH5

Figure 30. Localized High Temperature Zones

Table 45 provides maximum case temperatures for the Desktop Board D865GBF/D865GLC components that are sensitive to thermal changes. The operating temperature, current load, or operating frequency could affect case temperatures. Maximum case temperatures are important when considering proper airflow to cool the Desktop Board D865GBF/D865GLC.

Table 45. Thermal Considerations for Components

Component	Maximum Case Temperature
Intel® Pentium® 4 processor	For processor case temperature, see processor datasheets and processor specification updates
Intel® 82865G GMCH	99 °C (under bias)
Intel® 82801EB ICH5	115 °C (under bias)

For information about	Refer to
Intel Pentium 4 processor datasheets and specification updates	Section 1.3, page 17

ERRATA

1. ***Audio Driver Creates a Popping Noise During Operating System Startup***

PROBLEM: The audio jack-sensing feature requires reading the impedance of the device connected to the audio jack. A voltage is needed so a current can be measured, and the impedance is derived from the voltage and current. The application of the voltage results in a popping noise that is emitted from the speakers.

IMPLICATION: A popping noise from the speakers may be heard at the end of the operating system startup tune, while loading Microsoft Windows® operating systems.

WORKAROUND: None.

STATUS: This erratum will not be fixed.

2. ***Front Panel Audio Connector Signals Routed Incorrectly***

PROBLEM: The front panel audio connector pin definition is not correct. Pin 4 is defined as +5 V and should be ground. Pin 7 is defined as ground and should be +5V.

IMPLICATION: Front panel audio cards that route their +5 V rail to Pin 4 will not function correctly.

WORKAROUND: Front panel audio cards that require +5 V should route the +5 V rail to Pin 7.

STATUS: This erratum was fixed in hardware AA revisions C25827-403, C25843-403, C28142-403, C25840-403, C28140-403, and C28144-404 or later.

3. ***PCI Slot 4 Cannot be Used With Long PCI Add-in Cards***

PROBLEM: A tall capacitor is located one half inch behind PCI slot 4.

IMPLICATION: PCI cards conforming to the PCI specification may not be useable in PCI slot 4.

WORKAROUND: None.

STATUS: This issue may be fixed in a future hardware revision.

4. ***Some UDMA 6 Hard Disk Drives May Not Operate Properly***

PROBLEM: Some ATA-133 (UDMA 6) hard disk drives may not be properly recognized by the system BIOS to set the proper drive setting for ATA-100 (UDMA 5) operation that is supported by the Intel® D845GEBV2 desktop board.

IMPLICATION: If the ATA-133 hard disk drive is not properly set to UDMA 5 in the BIOS Setup/Advanced/IDE Configuration submenu, the user may experience failed operating system installation or other data corruption issues.

WORKAROUND: In the BIOS Setup/Advanced/IDE Configuration sub menu, the UDMA setting can be manually changed to UDMA 5.

STATUS: This issue is intended to be fixed in a future BIOS revision.

5. *PXE Boot is Inoperative When Using Some Add-in AGP Video Cards That Have 256 MB of Onboard Memory*

PROBLEM: Remote boot using PXE will not work when some add-in AGP video cards containing 256 MB of RAM are used.

IMPLICATION: Users that boot systems using PXE and also utilize add-in AGP video cards with 256 MB of memory may not connect to the remote server.

WORKAROUND: None.

STATUS: This erratum may be fixed in a future BIOS revision.

6. *PCI Slot 1 Cannot be Used With Long PCI Add-in Cards*

PROBLEM: A tall capacitor is located 3 ¼ inches behind PCI slot 1.

IMPLICATION: PCI cards conforming to the PCI specification but exceed 8 inches in length, may not be useable in PCI slot 1.

WORKAROUND: None.

STATUS: This erratum may be fixed in a future hardware revision.

7. *Advance Jack Sense May Not Recognize Devices Connected to a Front Panel Audio Port*

PROBLEM: The advanced jack sense with Auto Topology Switching, that is used by the audio codec to recognize what device is connected to an audio port, may fail to report devices connected to a front-panel port.

IMPLICATION: Devices connected through a front panel audio port will be detected and function correctly, but the advance jack sense wizard will only report the device at start up.

WORKAROUND: None.

STATUS: This erratum will not be fixed.

8. *Advance Jack Sense on Boards with 6-Channel Audio Will Report "Microphone" for Any Device Connected to the Back Panel Microphone Port (Pink)*

PROBLEM: For boards with 6-channel audio, the advanced jack sense with Auto Topology Switching, that is used by the audio codec to recognize what device is connected to an audio port, will report "Microphone" for any device connected to the back panel pink microphone port.

IMPLICATION: The advanced jack sense wizard will report any device connected through the back panel microphone port to be a "Microphone" and the wizard will prompt the user to verify this detection assumption.

Workaround: None.

Status: This erratum will not be fixed.

9. *Advance Jack Sense Will Not Detect Devices Connected to the Center/LFE and Surround Ports*

PROBLEM: Polling devices connected to the Center/LFE and Surround port would cause popping noise once speakers are connected. Due to this anomaly, the advance jack sense wizard will not poll and report devices connected to the Center/LFE and Surround ports although these devices will work correctly.

IMPLICATION: Devices connected to the Center/LFE or Surround port will be detected and function correctly, but the advance jack sense wizard will not poll and report the device.

WORKAROUND: None.

STATUS: This erratum will not be fixed.

10. *Advance Jack Sense May Report Amplified Speakers as an Array Microphone When Connected to The Microphone Port (Pink)*

PROBLEM: The presence of voltage bias on the microphone jack during the detection phase is required for accurate detection, but amplified speakers and array microphones have very similar impedance values.

IMPLICATION: Amplified speakers will be detected and function correctly, but the advance jack sense wizard may report the device as an array microphone.

WORKAROUND: None.

STATUS: This erratum will not be fixed.

11. *An Additional Reboot May Be Required After Installing Audio Drivers for Microsoft Windows 98SE or Windows ME*

PROBLEM: An application post-installer completes the driver installation and requires an additional reboot to get full functionality in Windows 98SE or Windows ME.

IMPLICATION: An additional reboot is required after installing audio drivers for Windows 98SE or Windows ME.

WORKAROUND: None.

STATUS: This erratum will not be fixed.

12. System Memory May Be Reduced in Excess of the Amount of AGP Aperture Size When 4GB of System Memory are Used

PROBLEM: The AGP aperture size setting in the system BIOS will consume, from available system memory, 2 times the amount applied in the AGP aperture setting when the maximum of 4 GB of system memory is installed.

IMPLICATION: When 4GB of system memory are used, and system memory is allocated to AGP aperture size in BIOS Setup, available system memory may be reduced by twice the amount allocated. A similar impact to available system memory may occur from any allocation of system memory when 4 GB of system memory is used. For example, increasing the video frame buffer in BIOS may also reduce available memory in excess of the amount requested.

WORKAROUND: None.

STATUS: This erratum may be fixed in a future BIOS revision.

13. Some Systems May Hang if the Mouse is Moved When Entering Standby Mode

PROBLEM: Moving the mouse after placing the system into standby with the mouse may cause the system to immediately awaken and hang.

IMPLICATION: The system may hang if the user is moving the mouse directly after using the mouse to place the system into standby mode.

WORKAROUND: None.

STATUS: This erratum may be fixed in a future board revision.

14. System May Intermittently Hang at POST Code 75 with SATA Hard Disk Drives Attached

PROBLEM: An intermittent hang at POST code 75 may be observed when SATA Hard Disk Drives are used. This intermittent hang is due to an erroneous circuit race condition in the system clock when spread spectrum is enabled by BIOS.

IMPLICATION: The system hang is exhibited when the system clock's internal circuitry is erroneously enabled when spread spectrum is enabled on PLL1.

WORKAROUND: The user will need to reset the system, which allows the SATA Hard Disk Drives to be reinitialized.

STATUS: This issue may be fixed in a future BIOS revision.

SPECIFICATION CLARIFICATIONS

The Specification Clarifications listed in this section apply to the *Intel® Desktop Board D865GBF/D865GLC Technical Product Specification* (Order Number C32634). All Specification Clarifications will be incorporated into a future version of that specification.

1. Add Note That Specifies Enhanced Mode IDE/Serial ATA Requirements to Section 3.3.2, PCI IDE Support

In section 3.3.2, PCI IDE Support, the following note will be added.

NOTE

The Enhanced mode IDE/Serial ATA BIOS option requires support for resources up to a maximum six devices, and has been tested with Windows 2000 and Windows XP. This BIOS option should be set to Legacy mode when used with operating systems that support a maximum of two IDE channels (four devices).

2. Updates to the Design Specifications Applicable to the Desktop Board D865GBF

Table 4, section 1.5, Design Specification will be replaced in its entirety as follows.

1.5 Design Specifications

Table 4 lists the specifications applicable to the Desktop Boards D865GBF and D865GLC.

Table 4. Specifications

Reference Name	Specification Title	Version, Revision Date, and Ownership	The information is available from...
AC '97	<i>Audio Codec '97</i>	Revision 2.2, September 2000, Intel Corporation.	ftp://download.intel.com/labs/media/audio/download/ac97r22.pdf
ACPI	<i>Advanced Configuration and Power Interface Specification</i>	Version 1.0b, February 08, 1999, Intel Corporation, Microsoft Corporation, and Toshiba Corporation.	http://www.acpi.info/spec10b.htm
AGP	<i>Accelerated Graphics Port Interface Specification</i>	Revision 3.0, September, 2002, Intel Corporation.	http://www.agpforum.org/specs_specs.htm
ASF	<i>Alert Standard Format (ASF) Specification</i>	Version 1.03, June 20, 2001, DMTF, Intel Corporation.	http://www.dmtf.org/standards/documents/ASF/DSF0114.pdf
ATA/ATAPI-5	<i>Information Technology-AT Attachment with Packet Interface - 5 (ATA/ATAPI-5)</i>	Revision 3, February 29, 2000, Contact: T13 Chair, Seagate Technology.	http://www.t13.org/
ATX	<i>ATX Specification</i>	Version 2.03, December 1998, Intel Corporation.	http://www.formfactors.org/developer/specs/atx/atxspecs.htm

continued

Table 4. Specifications (continued)

Reference Name	Specification Title	Version, Revision Date and Ownership	The information is available from...
ATX12V	<i>ATX/ATX12V Power Supply Design Guide</i>	Version 1.2, August 2000, Intel Corporation.	http://www.formfactors.org/developer/specs/atx/atxspecs.htm
BIS	<i>Boot Integrity Services (BIS) Application Programming Interface (API)</i>	Version 1.0, August 4, 1999, Intel Corporation.	http://www.intel.com/labs/manage/wfm/wfmspecs.htm
DDR SDRAM	<i>Double Data Rate (DDR) SDRAM Specification</i>	Version 1.0, June 2000, JEDEC Solid State Technology Association.	http://www.jedec.org/
	<i>Design Specification for a 184 Pin DDR Unbuffered DIMM</i>	Revision 1.0, October 2001, JEDEC Solid State Technology Association.	http://www.jedec.org/
	<i>Intel® JEDEC DDR 200/266 Unbuffered DIMM Specification Addendum</i>	Revision 0.9, September 27, 2001, Intel Corporation.	http://developer.intel.com/technology/memory/index.htm
EHCI	<i>Enhanced Host Controller Interface Specification for Universal Serial Bus</i>	Revision 1.0, March 12, 2002, Intel Corporation.	http://developer.intel.com/technology/usb/download/ehci-r10.pdf
EPP	<i>IEEE Std 1284.1-1997 (Enhanced Parallel Port)</i>	Version 1.7, 1997, Institute of Electrical and Electronic Engineers.	http://standards.ieee.org/reading/ieee/std_public/description/busarch/1284.1-1997_desc.html
El Torito	<i>Bootable CD-ROM Format Specification</i>	Version 1.0, January 25, 1995, Phoenix Technologies Limited and International Business Machines Corporation.	http://www.phoenix.com/resources/specs-cdrom.pdf

continued

Table 4. Specifications (continued)

Reference Name	Specification Title	Version, Revision Date and Ownership	The information is available from...
LPC	<i>Low Pin Count Interface Specification</i>	Revision 1.0, September 29, 1997, Intel Corporation.	http://www.intel.com/design/chipsets/industry/lpc.htm
MicroATX	<i>microATX Motherboard Interface Specification</i>	Version 1.0, December 1997, Intel Corporation.	http://www.formfactors.org/developer/specs/microatx/microatx.htm
PCI	<i>PCI Local Bus Specification</i>	Revision 2.2, December 18, 1998, PCI Special Interest Group.	http://www.pcisig.com/specifications
	<i>PCI Bus Power Management Interface Specification</i>	Revision 1.1, December 18, 1998, PCI Special Interest Group.	http://www.pcisig.com/specifications
Plug and Play	<i>Plug and Play BIOS Specification</i>	Version 1.0a, May 5, 1994, Compaq Computer Corporation, Phoenix Technologies Limited, and Intel Corporation.	http://www.microsoft.com/hwdev/tech/PnP/default.asp
PXE	<i>Preboot Execution Environment</i>	Version 2.1, September 20, 1999, Intel Corporation.	ftp://download.intel.com/abs/manage/wfm/download/pxespec.pdf
SFX	<i>SFX/SFX12V Power Supply Design Guide</i>	Version 2.0, May 2001, Intel Corporation.	http://www.formfactors.org/developer/specs/sfx/sfx12v.pdf

continued

Table 4. Specifications (continued)

Reference Name	Specification Title	Version, Revision Date and Ownership	The information is available from...
SMBIOS	<i>System Management BIOS</i>	Version 2.3.1, March 16, 1999, American Megatrends Incorporated, Award Software International Incorporated, Compaq Computer Corporation, Dell Computer Corporation, Hewlett-Packard Company, Intel Corporation, International Business Machines Corporation, Phoenix Technologies Limited, and SystemSoft Corporation.	http://www.dmtf.org/download/standards/DSP0119.pdf
TFX12V	<i>TFX12V Power Supply Design Guide</i>	Revision 1.01, May 2002, Intel Corporation.	http://www.formfactors.org/developer/specs/tfx12v/tfx12v_psdg_101.pdf
UHCI	<i>Universal Host Controller Interface Design Guide</i>	Revision 1.1, March 1996, Intel Corporation.	http://developer.intel.com/design/USB/UHCI11D.htm
USB	<i>Universal Serial Bus Specification</i>	Revision 2.0, April 27, 2000, Compaq Computer Corporation, Hewlett-Packard Company, Lucent Technologies Inc., Intel Corporation, Microsoft Corporation, NEC Corporation, and Koninklijke Philips Electronics N.V.	http://www.usb.org/developers/docs

3. **Change to Description of Table 28, Front Panel Audio Connector**

Table 28, Front Panel Audio Connector will change in its entirety as follows:

Table 28. Front Panel Audio Connector

Pin	Signal Name	Pin	Signal Name
1	Mono Mic in (Stereo Mic 1)	2	Ground
3	Mono Mic Bias (Stereo Mic 2)	4	+5 V
5	RIGHT_OUT	6	Right channel return
7	No connect	8	Key
9	LEFT_OUT	10	Left channel return

INTEGRATOR'S NOTE

The front panel audio connector is alternately used as a jumper block for routing audio signals. Refer to Section 2.9.1 on page 83 for more information.

4. **Clarification of SMBus Routing**

Section 2.8.2.1 will change in its entirety as follows:

2.8.2.1 Expansion Slots

The board has the following expansion slots:

- AGP connector: The AGP connector is keyed for Universal 0.8 V AGP 3.0 cards or 1.5 V AGP 2.0 cards only. Do not install a legacy 3.3 V AGP card. The AGP connector is not mechanically compatible with legacy 3.3 V AGP cards.
- PCI rev 2.2 compliant local bus slots (six on the Desktop Board D865GBF, three on the Desktop Board D865GLC). The SMBus is routed to PCI bus connector 2 only (ATX expansion slot 6). PCI add-in cards with SMBus support can access sensor data and other information residing on the Desktop Board.

NOTE

The SMBus routing to the PCI bus connectors does not conform to the PCI Engineering Change Notice (ECN) "Addition of the SMBus to the PCI Connector ECN", dated October 5th, 2000. The ECN specifies that SMBus signals must be

routed to all PCI bus connectors. On this board, SMBus signals are routed to PCI bus connector 2 only.

Add-in cards that implement PCI bus connector pins A40 and A41 for any purpose other than SMBCLK (SMBus clock) and SMBDAT (SMBus data) should not be installed in PCI bus connector 2.

For information about

Addition of the SMBus to the PCI Connector ECN

Refer to

http://www.pcisig.com/data/specifications/smb_ecn_0405_01.pdf

⇒ NOTE

This document references back-panel slot numbering with respect to processor location on the board. The AGP slot is not numbered. PCI slots are identified as PCI slot #x, starting with the slot closest to the processor. Figure 21 (page 76) and Figure 22 (page 77) illustrate the board's PCI slot numbering.

5. Clarification of DDR Voltage

Section 1.7, System Memory, will change as follows:

1.7 System Memory

The Desktop Boards D865GBF and D865GLC have four DIMM sockets and support the following memory features:

- 2.6 V (only) 184-pin DDR SDRAM DIMMs with gold-plated contacts
- Unbuffered, single-sided or double-sided DIMMs with the following restriction:
 - Double-sided DIMMs with x16 organization are not supported.
- 4 GB maximum total system memory. Refer to Section 2.2.1 on page 59 for information on the total amount of addressable memory.
- Minimum total system memory: 64 MB
- Non-ECC DIMMs
- Serial Presence Detect
- DDR400, DDR333, and DDR266 SDRAM DIMMs

6. Clarification of Section 2.11.1, DC Loading

Clarification to Section 2.11.1, DC Loading, will be added as follows:

2.11.1 DC LOADING

Table 43 lists the DC loading characteristics of the board. This data is based on a DC analysis of all active components within the board that impact its power delivery subsystems. The analysis does not include PCI add-in cards. Minimum values assume a light load placed on the board that is similar to an environment with no applications running and no USB current draw. Maximum values assume a load placed on the board that is similar to a heavy gaming environment with a 500 mA current draw per USB port. These calculations are not based on specific processor values or memory configurations but are based on the minimum and maximum current draw possible from the board's power delivery subsystems to the processor, memory, and USB ports.

Use the datasheets for add-in cards, such as PCI and AGP, to determine the overall system power requirements. The selection of a power supply at the system level is dependent on the system's usage model and not necessarily tied to a particular processor speed.

7. Change to Description of Section 2.11.3, Fan Connector Current Supply, Correction of Processor and Voltage Regulator Fan Current

Section 2.11.3, Fan Connector Current Supply will change in its entirety as follows:

2.11.3 FAN CONNECTOR CURRENT CAPABILITY



CAUTION

The processor fan must be connected to the processor fan connector, not to a chassis fan connector. Connecting the processor fan to a chassis fan connector may result in onboard component damage that will halt fan operation.

Table 44 lists the current capability of the fan connectors.

Table 44. Fan Connector Current Capability

Fan Connector	Maximum Available Current
Processor fan	1600 mA
Front chassis fan	600 mA
Rear chassis fan	600 mA

8. Change to Description of Section 2.9.1, Front Panel Audio Connector/Jumper Block

Section 2.9.1, Front Panel Audio Connector/Jumper Block will change in its entirety as follows:

2.9.1 FRONT PANEL AUDIO CONNECTOR/JUMPER BLOCK

This connector has two functions:

- With jumpers installed, the audio line out signals are routed to the back panel audio line out connector.
- With jumpers removed, the connector provides audio line out and mic in signals for front panel audio connectors.

Table 41 describes the two configurations of this connector/jumper block.



CAUTION

Do not place jumpers on this block in any configuration other than the one described in Table 41. Other jumper configurations are not supported and could damage the Desktop Board.

Table 41. Front Panel Audio Connector/Jumper Block

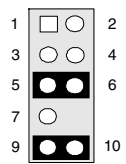
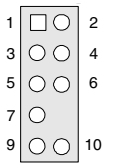
Jumper Setting	Configuration
 <p>1 2 3 4 5 6 7 9 10</p> <p>5 and 6 9 and 10</p>	<p>Audio line out signals are routed to the back panel audio line out connector. The back panel audio line out connector is shown in Figure 18 on page 69.</p>
 <p>1 2 3 4 5 6 7 9 10</p> <p>No jumpers installed</p>	<p>Audio line out and mic in signals are available for front panel audio connectors. Table 28 on page 72 lists the names of the signals available on this connector when no jumpers are installed.</p>



INTEGRATOR'S NOTE

When the jumpers are removed and this connector is used for front panel audio, the back panel audio line out and mic in connectors are disabled.

DOCUMENTATION CHANGES

The Documentation Changes listed in this section apply to the *Intel® Desktop Board D865GBF/D865GLC Technical Product Specification* (Order Number C32634). All Documentation Changes will be incorporated into a future version of that specification.

1. **Removal of Intel® Branding From Subtitle of Section 1.10.2**

Section 1.10.2 Subtitle will change as follows:

1.10.2 FLEX 6 AUDIO SUBSYSTEM

2. **Change to Description of 10/100 LAN LED States**

Table 13, Section 1.11.1.2, RJ-45 LAN Connector with Integrated LED's, will change in its entirety as follows:

Table 13 LAN Connector LED States

LED Color	LED State	Condition
Green	Off	LAN link is not established.
	On	LAN link is established.
	Blinking	LAN activity is occurring.
Yellow	Off	10 Mbits/sec data rate is selected.
	On	100 Mbits/sec data rate is selected.

3. **Change to Description of Gigabit LAN LED States**

Table 14, Section 1.11.2.2, RJ-45 LAN Connector with Integrated LED's, will change in its entirety as follows:

Table 14. LAN Connector LED States

LED	Color	LED State	Condition
Left	Green	Off	LAN link is not established.
		On	LAN link is established.
		Blinking	LAN activity is occurring.
Right	N/A	Off	10 Mbit/sec data rate is selected.
	Green	On	100 Mbit/sec data rate is selected.
	Yellow	On	1000 Mbit/sec data rate is selected.